

# Panasonic Service and Technology Company

## Technical Guide

### 10<sup>th</sup> Generation Plasma Display Television



National Training

# Panasonic Service and Technology Company

Prepared by  
**Cesar Perdomo and Jean Magloire**  
Panasonic Service and Technology Company  
**National Training**

Copyright © 2007 by Panasonic Services Company  
All rights reserved. Unauthorized copying and distribution is a violation of law.

## **Warning**

This service information is designed for experienced repair technicians only and is not designed for use by the general public. It does not contain warnings or cautions to advise non-technical individuals of potential dangers in attempting to service a product. Products powered by electricity should be serviced or repaired only by experienced professional technicians. Any attempt to service or repair the product or products dealt with in this service information by anyone else could result in serious injury or death.

# Table of Contents

Subject	Page #	Subject	Page #
2007 Panasonic Plasma Line-up	5	Troubleshooting (No Power/Dead Unit) Part 2	56
Models Comparison	6	SOS Circuit Overview	59
High Resolution (FULL-HD Panel)	9	DRV_RST SOS	62
TH-42PX75U Board Layout & Description	13	Location of Q9302	63
TH-42PX75U Board Layout (Pictorial)	14	Close-up View of Q9302	64
2006/2007 Signal Process/Switching Circuit	15	5 Blinks SOS (1)	66
Overall Block Diagram	16	SOS (Drive-reset)	68
Standby Circuit	21	D & C Boards Connection	69
STB5V/STB3.3V Distribution	25	12 Blinks SOS	70
Main CPU VCC Supply (A Board)	28	Signal Circuit Overview	75
TV_SUB_ON/TUNER_SUB_ON	30	Video Process Block Diagram	77
TV_SUB_ON (F_STB_ON)	32	D Board Block Diagram	79
TV_SUB_ON (Relay Drive Circuit)	34	Panel Drive (TH-42PX75U)	81
PFC Circuit	36	Audio Process Block Diagram	83
ACFB (Active Clamp Full Bridge Switching) Circuit	37	Self-Check Function	88
MAIN/SUB Voltages	39	How to Reset the Unit	89
F+15V, DTV9V, SUB5V SOS Detect Circuit	41	Self-Check Menu	90
Power On Operation	43	Check point	91
P15V/P5V Circuit	51	Serviceman Mode	92
Vsus/Vda Circuit	53	Serviceman Mode Menu and Navigation	93
Troubleshooting (No Power/Dead Unit) Part 1	55	Internal Test Patterns	95

# Table of Contents (Continued)

Subject	Page #
Driver Setup Adjustment	96
Initialization Pulse Adjustment	97
Quick adjustment after P.C.B. exchange	98

# 2007 Panasonic Plasma Line-up

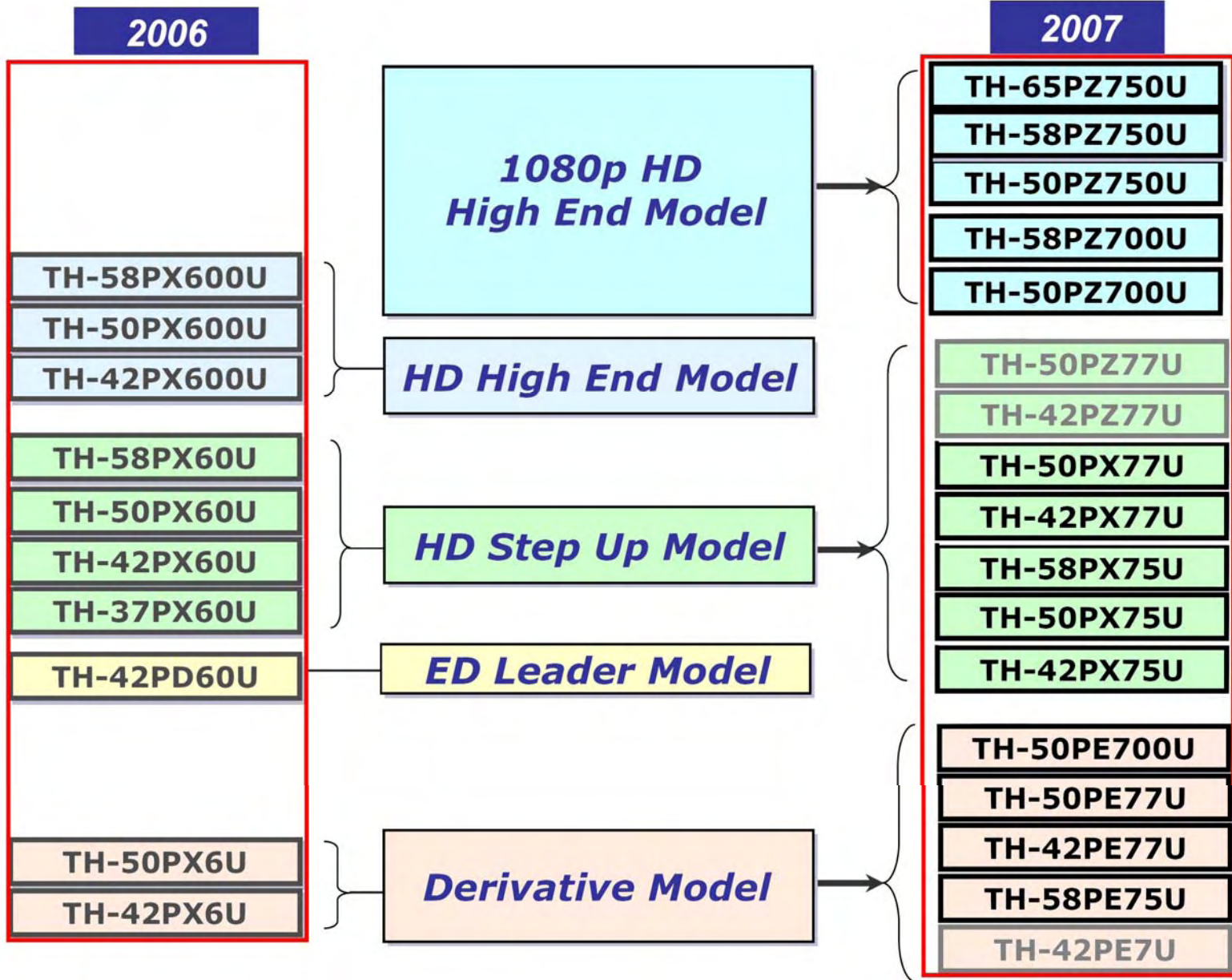



# Models Comparison

		PZ750 Series	PZ700 Series	PX77 Series	PX75 Series
Picture	Size	65/58/50	58/50	50/42	58/50/42
	Panel	1080p HD	1080p HD	HD	HD
	Gradation	4,096	4,096	3,072	3,072
	Contrast Ratio	Max. 5,000:1	Max. 5,000:1	Max. 10,000:1	Max. 10,000:1
	Digital Optimizer	Y	Y	Y	Y
	Cinema Mode	Y	-	-	-
	Advanced 3D Colour Management	Y	Y	Y	Y
	Motion Pattern Noise Reduction	Y	Y	Y	Y
	Sub-Pixel Controller	Y	Y	Y	Y
Sound	Speaker	Advanced Smart Sound Speaker (Side)	Advanced Smart Sound Speaker (Side)	Bottom Speaker	Bottom Speaker
	Cone Material	Bamboo fiber	Bamboo fiber	Bamboo fiber	-
	BBE VIVA	Y	Y	-	-
Networking	HDMI	3	2	2	2
	EZ Sync (HDAVI Control 2)	Y	Y	Y	Y
	SDHC Card Slot	Y (AVCHD/MPEG2/ JPEG*)	Y (JPEG*)	Y (JPEG*)	Y (JPEG*)
	Gallery Player	Y	Y	Y	Y
	PC Input	Y	Y	-	-

# Models Comparison

	TH-65PZ750U	TH-58PZ750U	TH-50PZ750U	TH-58PZ700U	TH-50PZ700U
Screen Size Diagonal (inches)	65	58	50	58	50
Number of Pixels	2,073,600 (1,920 x 1,080)	2,073,600 (1,920 x 1,080)	2,073,600 (1,920 x 1,080)	2,073,600 (1,920 x 1,080)	2,073,600 (1,920 x 1,080)
Pixel Pitch (mm)	0.747 x 0.747 mm	0.67 x 0.67 mm	0.576 x 0.576 mm	0.67 x 0.67 mm	0.576 x 0.576 mm
HDTV Display Capability (1080p, 1080i, 720p)	Y	Y	Y	Y	Y
Cinema Mode (with Pro Setting)	Y	Y	Y	-	-
BBE <sup>®</sup> ViVA HD3D Sound	Y	Y	Y	Y	Y
SD Memory Card Slot (SDHC Compatible)	Y (H.264/MPEG-2 playback)	Y (H.264/MPEG-2 playback)	Y (H.264/MPEG-2 playback)	Y	Y
HDMI Input	3 (1 front)	3 (1 front)	3 (1 front)	2	2
Composite Video Input	3 (1 front)	3 (1 front)	3 (1 front)	3 (1 front)	3 (1 front)
S-Video Input	3 (1 front)	3 (1 front)	3 (1 front)	3 (1 front)	3 (1 front)
PC Input	Mini D-sub 15-pin x 1 (rear)	Mini D-sub 15-pin x 1	Mini D-sub 15-pin x 1 (rear)	Mini D-sub 15-pin x 1 (rear)	Mini D-sub 15-pin x 1 (rear)

# Models Comparison

	TH-50PX77U	TH-42PX77U	TH-58PX75U	TH-50PX75U	TH-42PX75U
Screen Size Diagonal (inches)	50	42	58	50	42
Aspect Ratio	16:9	16:9	16:9	16:9	16:9
Number of Pixels	1,049,088 (1,366 x 768)	786,432 (1,024 x 768)	1,049,088 (1,366 x 768)	1,049,088 (1,366 x 768)	786,432 (1,024 x 768)
Pixel Pitch (mm)	0.81 x 0.81 mm	0.90 x 0.675 mm	0.942 x 0.942 mm	0.81 x 0.81 mm	0.90 x 0.675 mm
HDTV Display Capability (1080p, 1080i, 720p)	Y	Y	Y	Y	Y
Cinema Mode (with Pro Setting)	-	-	-	-	-
BBE <sup>®</sup> VIVA HD3D Sound	-	-	-	-	-
SD Memory Card Slot (SDHC Compatible)	Y	Y	Y	Y	Y
HDMI Input	2	2	2	2	2
Composite Video Input	3 (1 side)	3 (1 side)	2 	2	2
S-Video Input	3 (1 side)	3 (1 side)	2	2	2
PC Input	-	-	-	-	-



# High Resolution (FULL-HD Panel)

The Full-HD plasma panel boasts a total of about 2,070,000 pixels (1920 x 1080). It renders true-to-life HD images with about twice the resolution of a standard HD panel.

HD PDP  
(approx. 1,050,000 pixels)

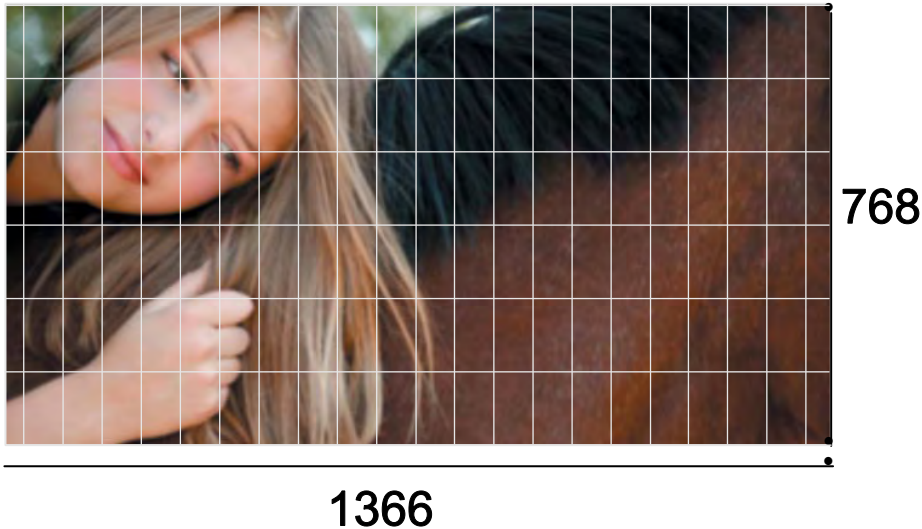

Full-HD PDP  
(approx. 2,070,000 pixels)

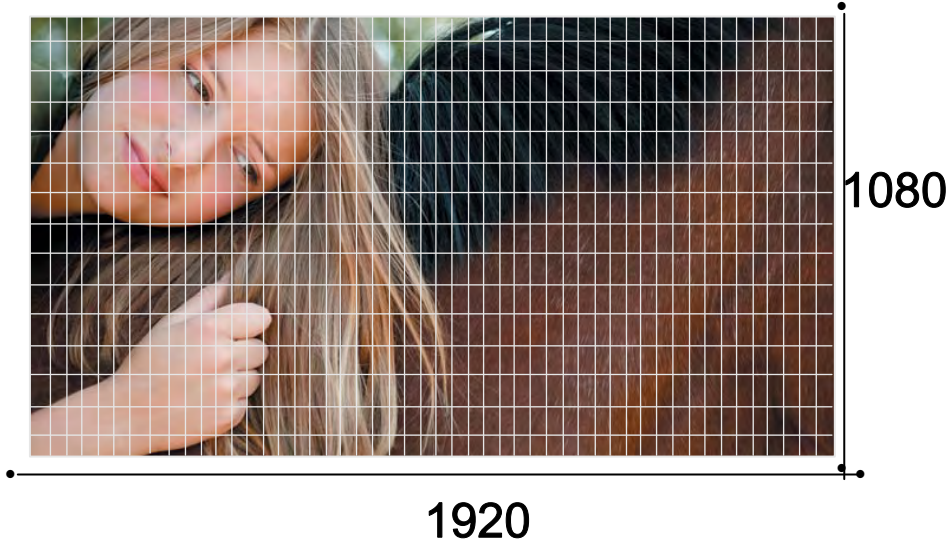

(Image resolution about twice as high) \*When compared to the 50PX600

**About Twice the Resolution of a Standard HD PDP!**



## *Board Layout*





# TH-42PX75U Boards Layout & Description

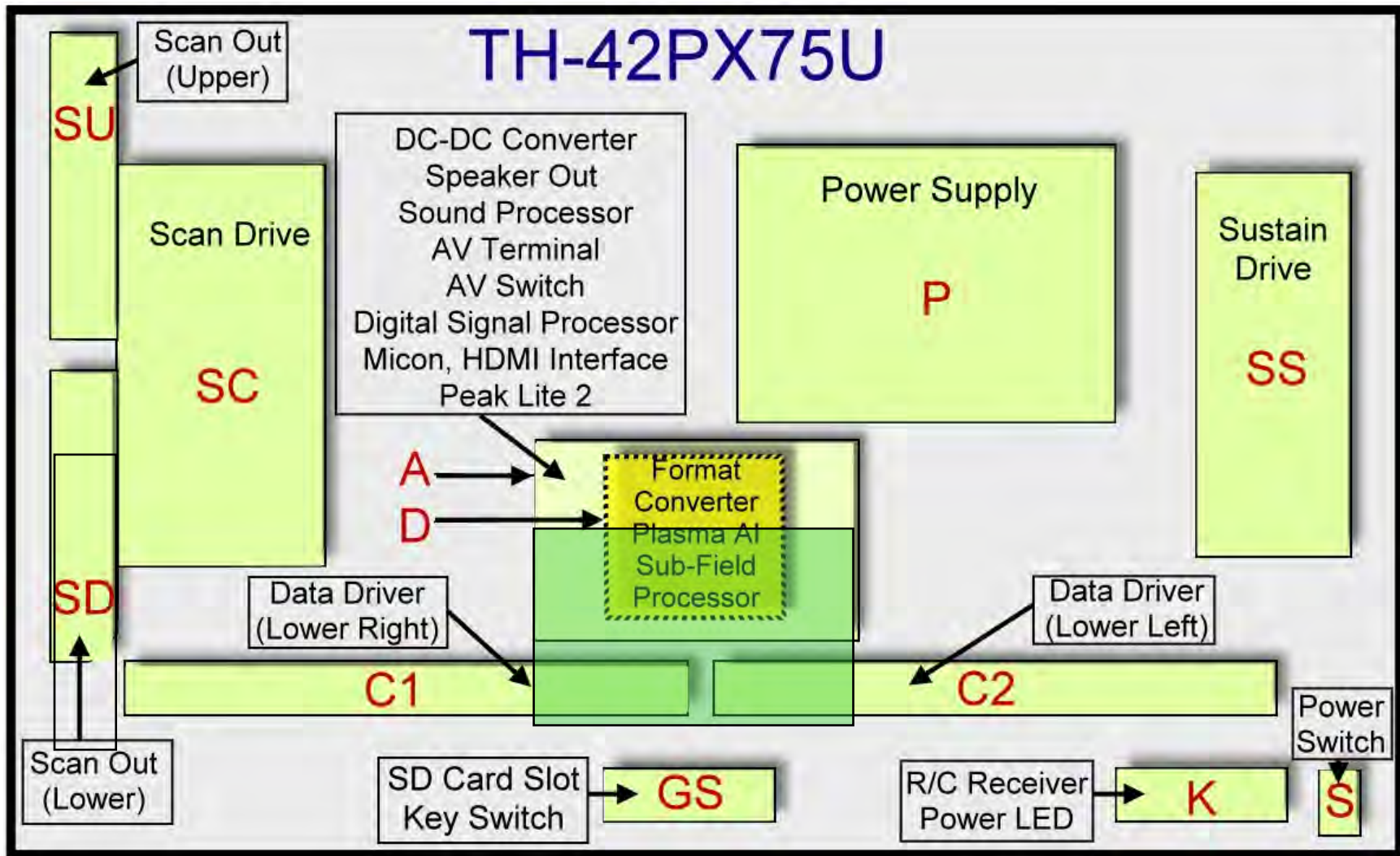

Panasonic started using single scan addressing in the 42" HD models last year when the 9th generation of Plasma TV was introduced. The single scan addressing was only used on standard definition models previously. For this generation, Panasonic has added the 50" models to the list of TV using single scan addressing.



# TH-42PX75U Board Layout (Pictorial)

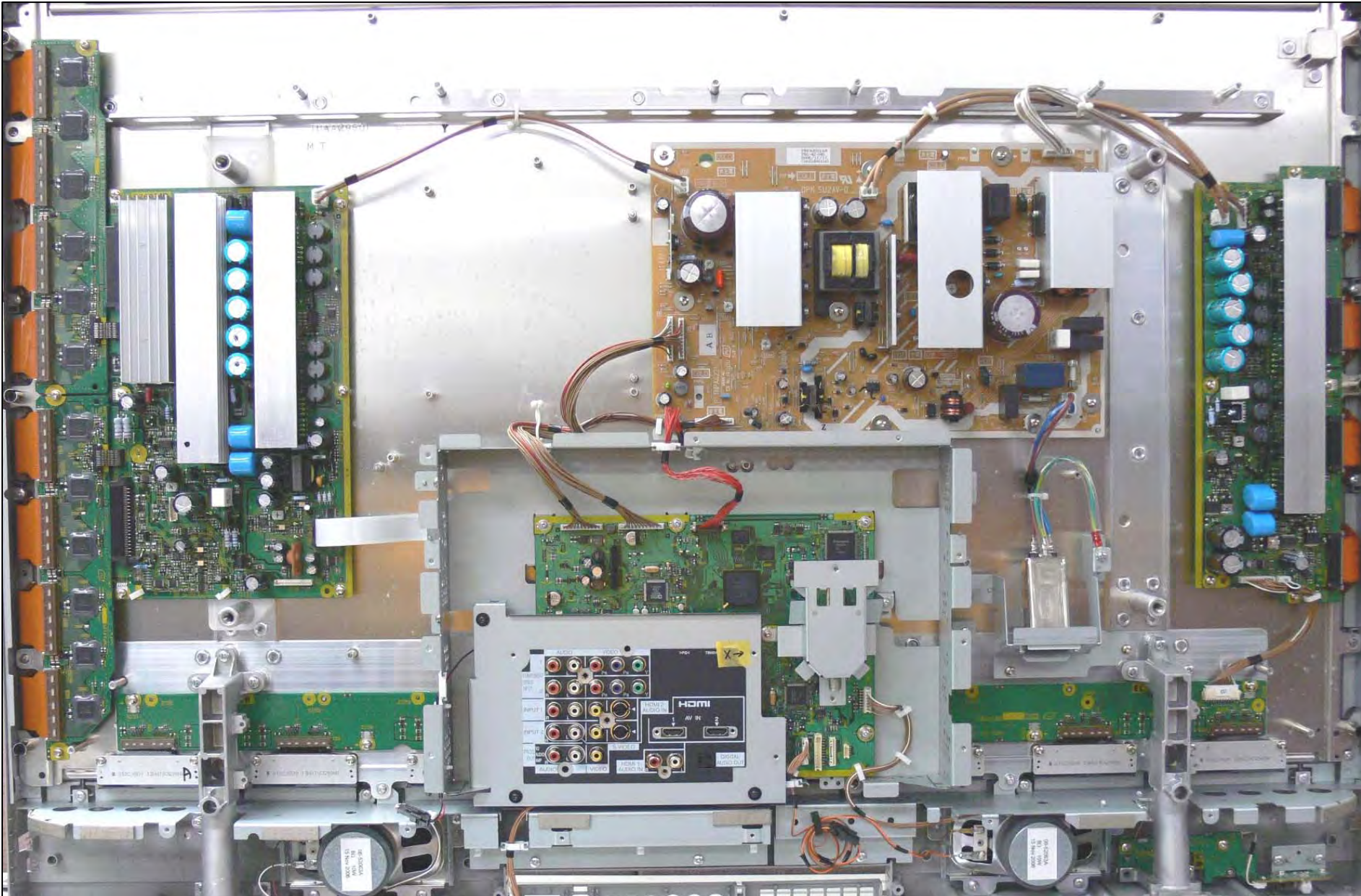



# 2006/2007 Signal Process/Switching Circuit

**2006**

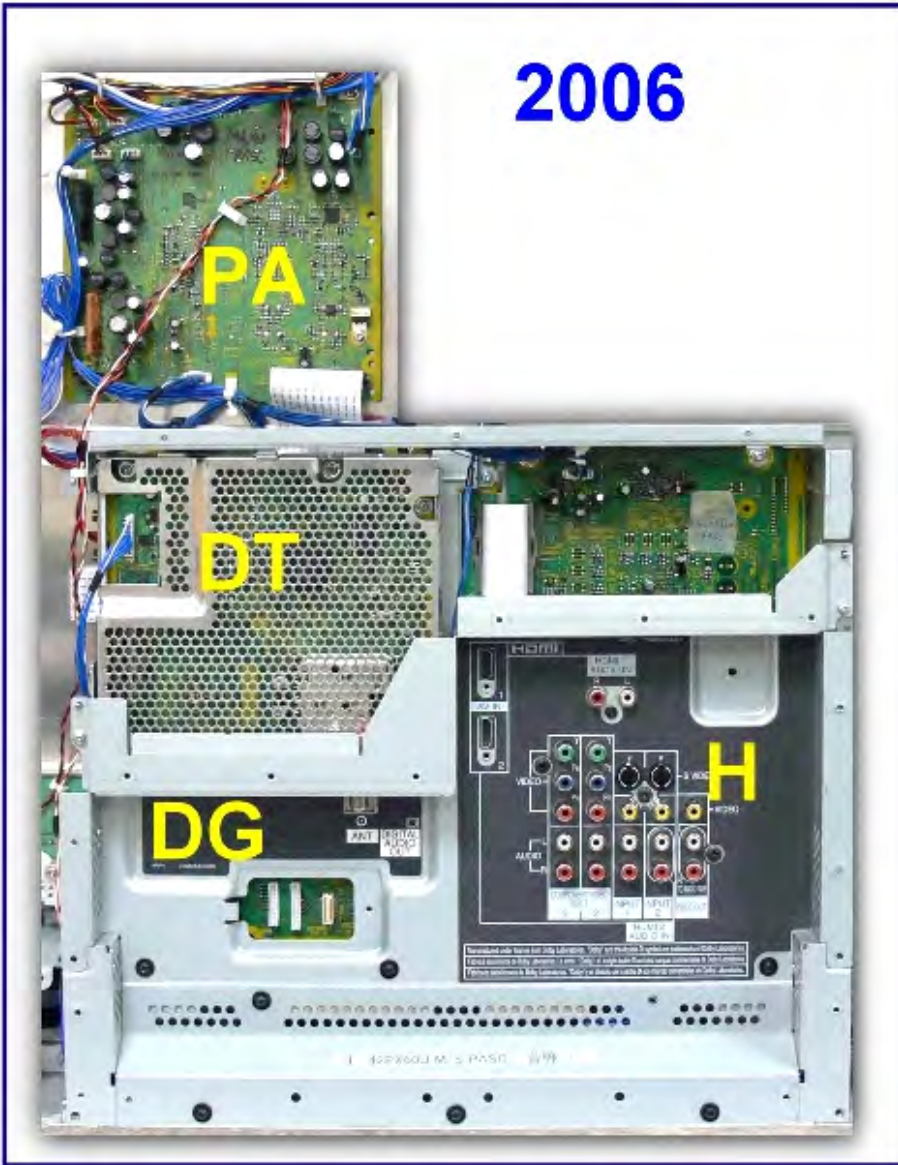

**2007**

The 2007 42" plasma models have less boards than the previous generation. The PA, DT, DG, H, and HC boards used on the 2006 42" models are now incorporated within the new A board of the 2007 models.



# Overall Block Diagram

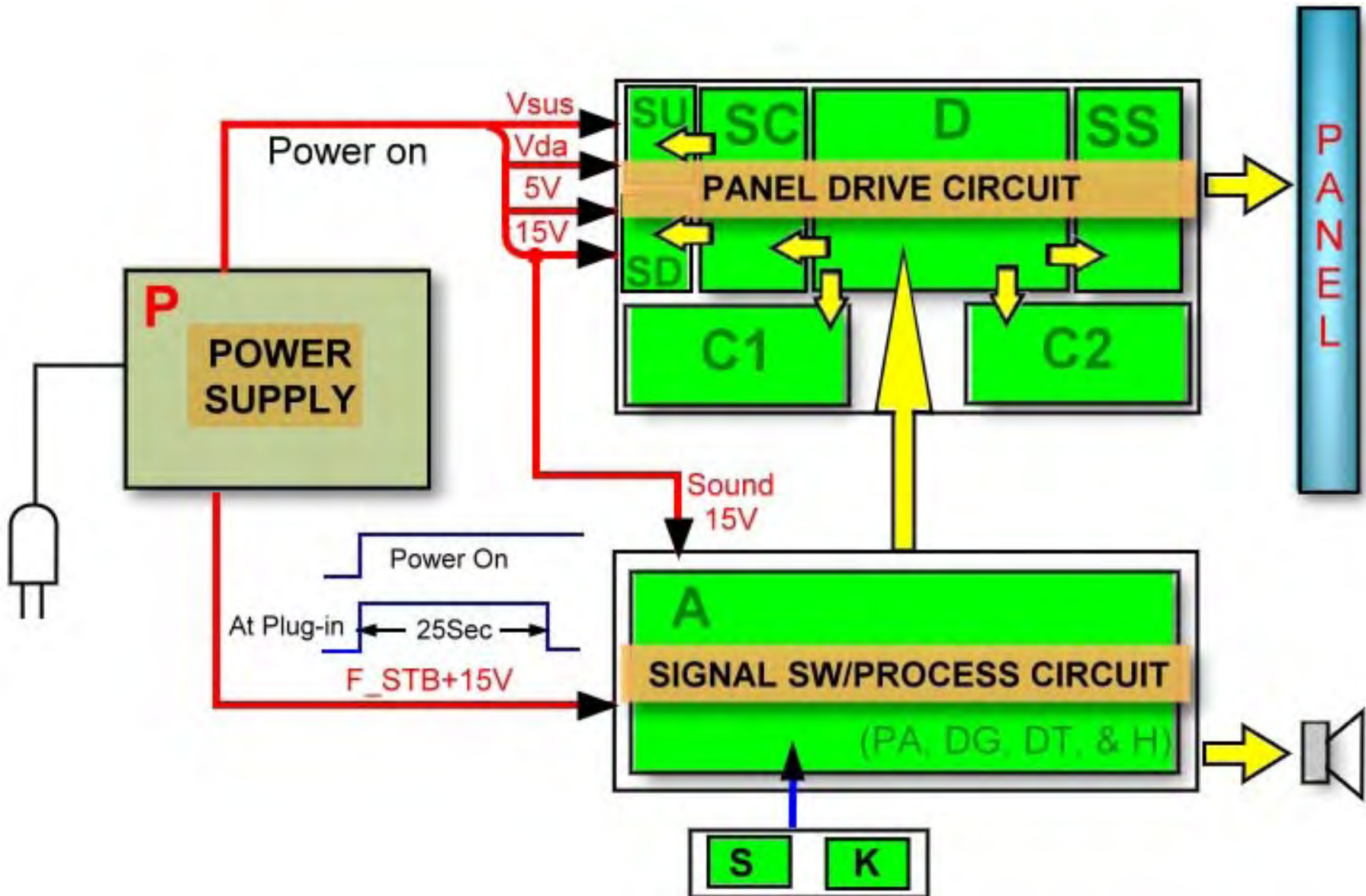



# Overall Block Diagram

The operation of the plasma TV can be divided into 3 different sections:

1. Power Supply Circuit

The power supply circuit board (P board) provides voltages to the Signal switching/processing circuit and the Panel drive circuit.

2. Signal Switching/Processing Circuit

Upon connecting the unit to the AC voltage source, the STB5V of the P board is provided to the A board for system control operation. The F\_STB15V is also provided to the signal switching/processing circuit of the A board. It remains present for approximately 25 seconds unless the power button is pressed. This circuit also receives 15V for audio operation and fan drive for models with fan.

3. Panel Drive Circuit.

The Panel drive circuit receives the Vsus, Vda, 15V, and 5V sources from the P board when the unit is in operation.



## *Power Supply*





# Standby Circuit

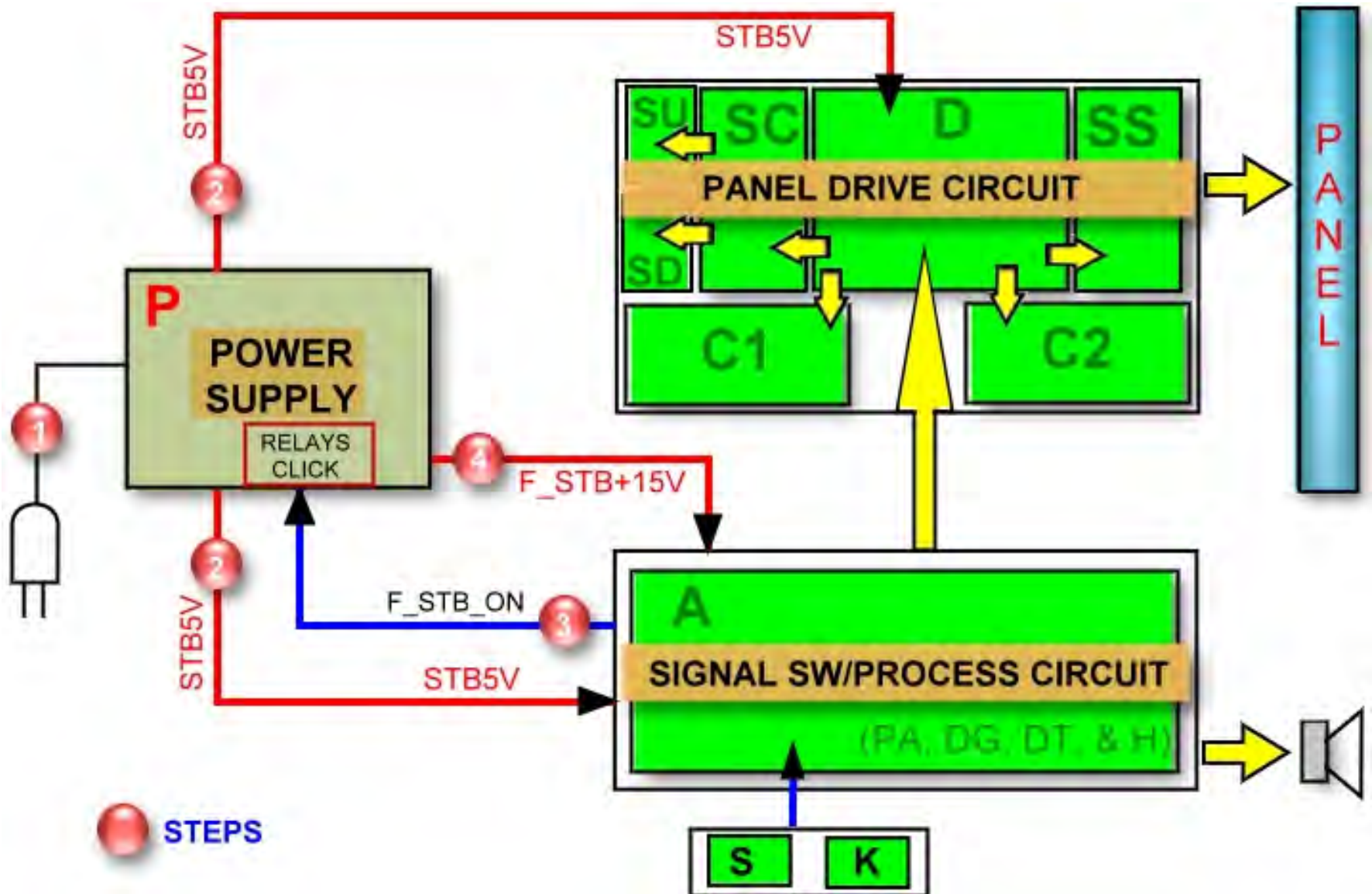

# Standby Circuit

1. When the TV is connected to the AC line, the power supply outputs 5V.
2. This voltage is applied to the D board and the A board. The 5V applied to the D board in the Panel Drive Section is not used during standby operation.
3. On the other hand, when the A board receives the 5V from the Power supply, it outputs the "F\_STB\_ON" command.
4. This command is applied to the power supply board to generate the F\_STB15V. The F\_STB15V is applied to the A board to energize the Signal SW/Process Circuit.

# Standby Circuit

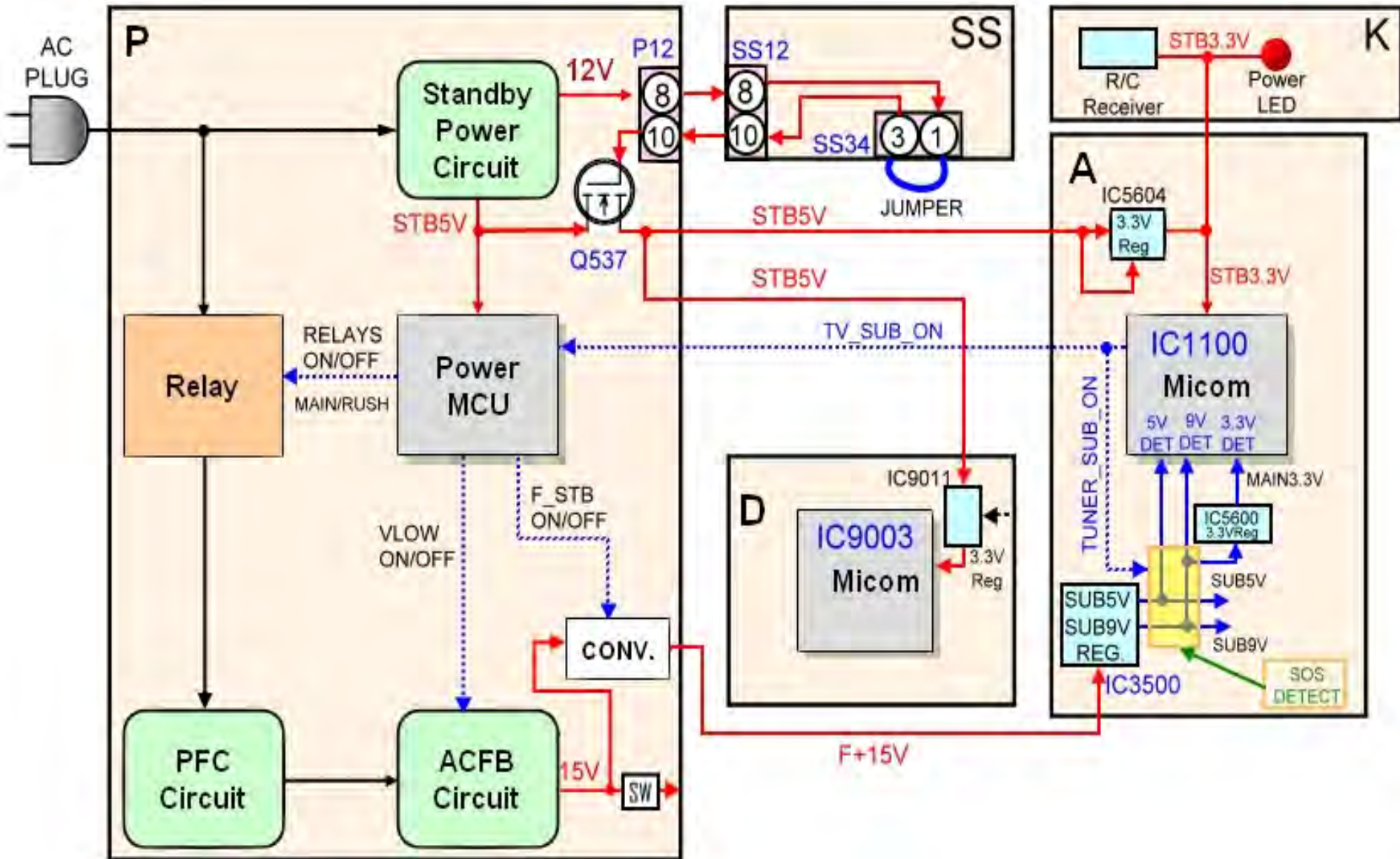

# Standby Circuit

When AC is applied to the TV, the Standby circuit outputs 5Vdc and 12Vdc. The 5V is applied to the Power MCU and the switching transistor Q537 of the power supply circuit. The 12V is provided to the SS board. A jumper at connector SS34 of the SS board routes the 12V back into the power supply board to turn on Q537. When Q537 is on, the STB5V is output to the D and A boards. On the D board, the STB5V is applied to a 3.3V regulator (IC9011). During standby operation, this regulator is kept off to disable the panel drive circuits. The STB5V is also applied to a 3.3V regulator (IC5604) on the A board to provide the supply voltage (STB3.3V) to the Main CPU (IC1100). The STB3.3V is also applied the Remote Control receiver and the power LED on the K board. Furthermore, the STB3.3V is provided to the SD card slot (Not shown in the diagram).

When the Main CPU IC1100 receives the 3.3V, it outputs the TV\_SUB\_ON/TUNER\_SUB\_ON command to the Power MCU (IC501) located on the Power Supply board. Subsequently, the power MCU outputs the following commands:

1. **Relays ON/OFF** \_ To turn on the circuit that activates on the AC relays. The PFC (Power Factor Control) circuit goes into operation to create the DC voltage needed to power the ACFB circuit.
2. **VLOW ON/OFF** \_ to turn on the ACFB (Active Clamp Full Bridge) circuit to generate the 15V.
3. **F\_STB\_ON/OFF**\_ to provide the command to turn on the DC-DC converter to output the F+15V.

The F+15V is applied to the 5V/9V regulator, IC3500, on the A board. The voltage outputs of IC3500 are used by various circuits on the A board. To avoid catastrophic failures, they are monitored by an SOS Detect circuit for over-voltage and over-current conditions. This SOS Detect circuit is controlled by the TUNER\_SUB\_ON command from the Main CPU (IC1100). The 9V from IC3500 is also applied to a 3.3V regulator (IC5600). The 5V and 9V from IC3500 and the 3.3V from IC5600 are connected to the CPU for voltage presence detection.



# STB5V/STB3.3V Distribution

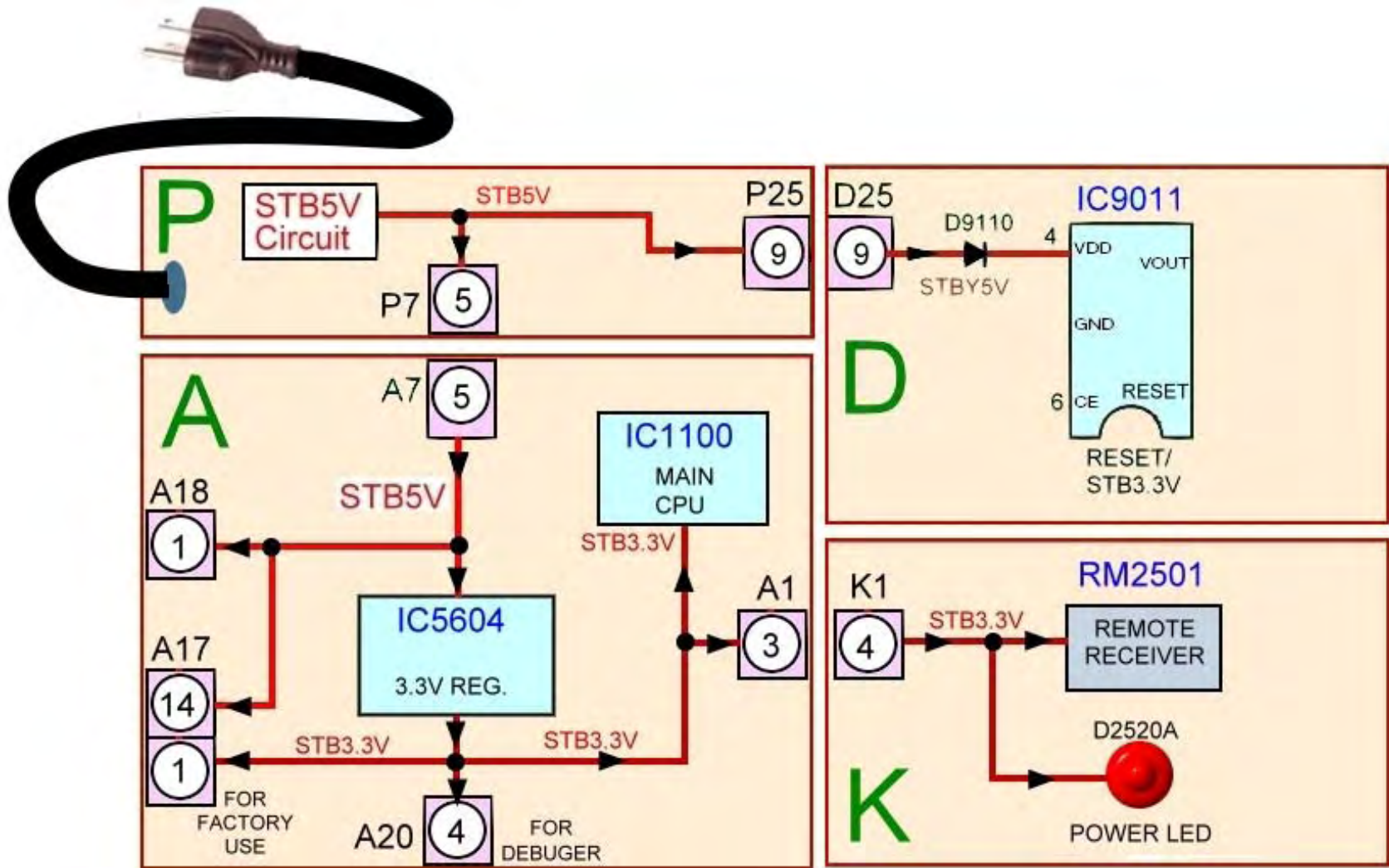

The STB5V is connected to the D and A boards. During standby, this voltage is not used by the D board. On the A board, the STB5V is applied to a 3.3V regulator (IC5604) to generate the STB3.3V to power the MAIN MICON Genx4 (IC1100). The STB3.3V is also connected to the remote receiver IC and the power LED on the K board.

# STB5V (2)

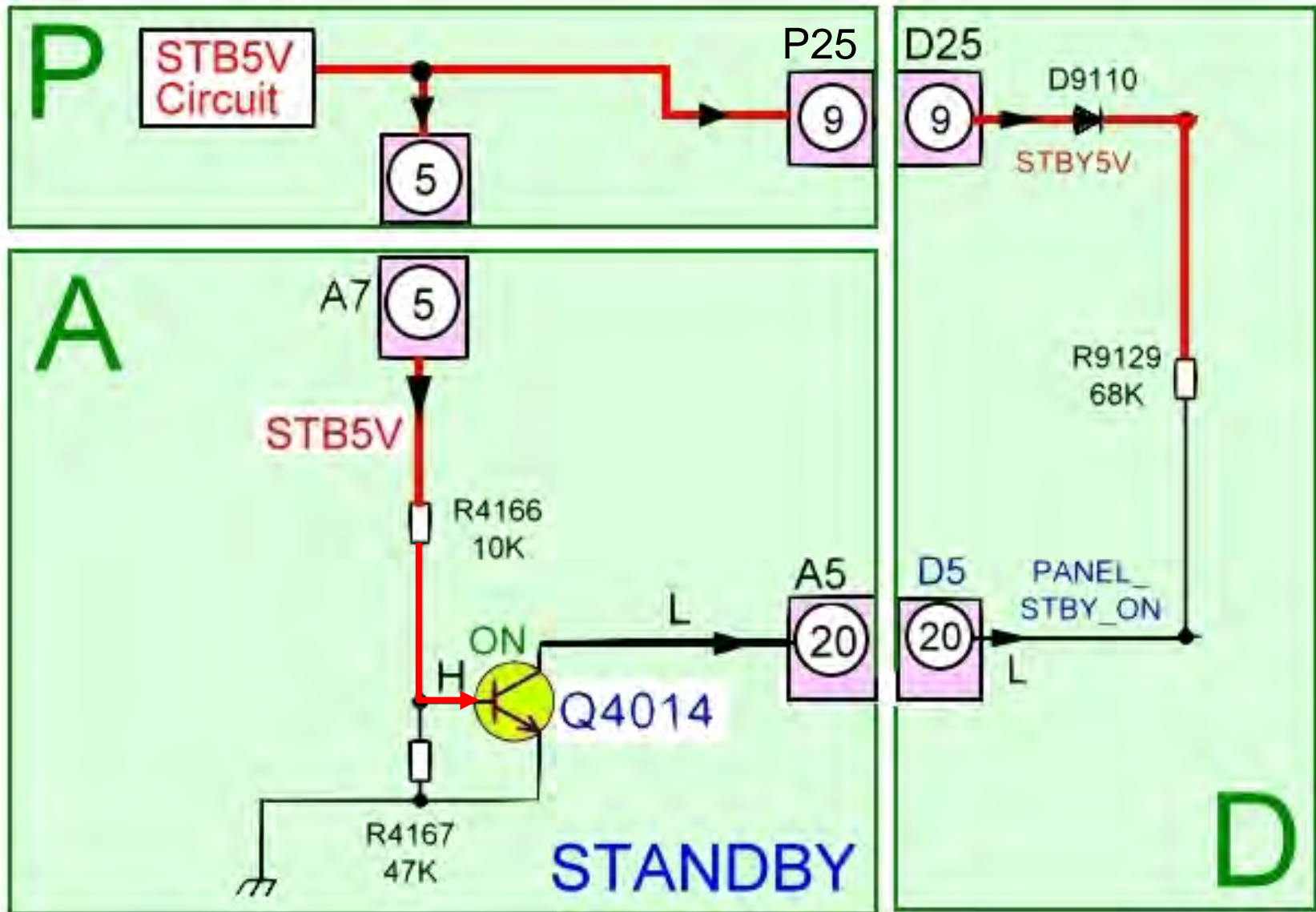

This circuit combined with the circuit in the following page is used to explain the reason why the CPU (IC9003) on the D board is not active during Standby. The transistor Q9014 is on to keep PANEL\_STBY\_ON low.

# STB5V (3)

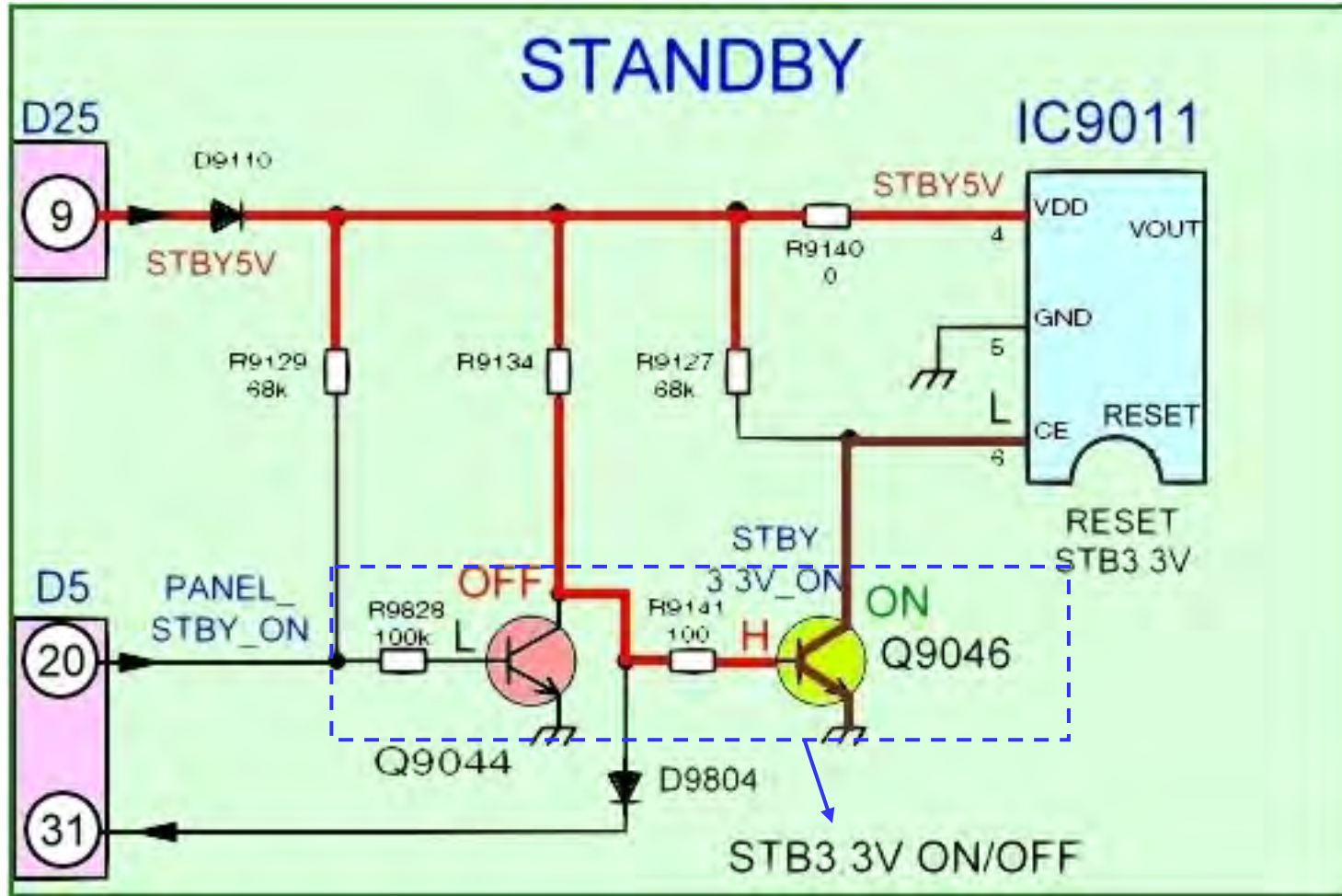

The STB5V source is connected to the voltage input (pin 4) of the RESET/STB3.3V regulator IC9011. The output of this IC is controlled by the ON/OFF pin (Pin 6). The DC level of this pin is determined by the "STB3.3V ON/OFF" circuit.

During standby pin 6 of IC9011 is low keeping IC9011 off. When the power is turned on; pin 6 goes high, the IC turns on and outputs 3.3V on pin 3.



# Main CPU VCC Supply (A Board)

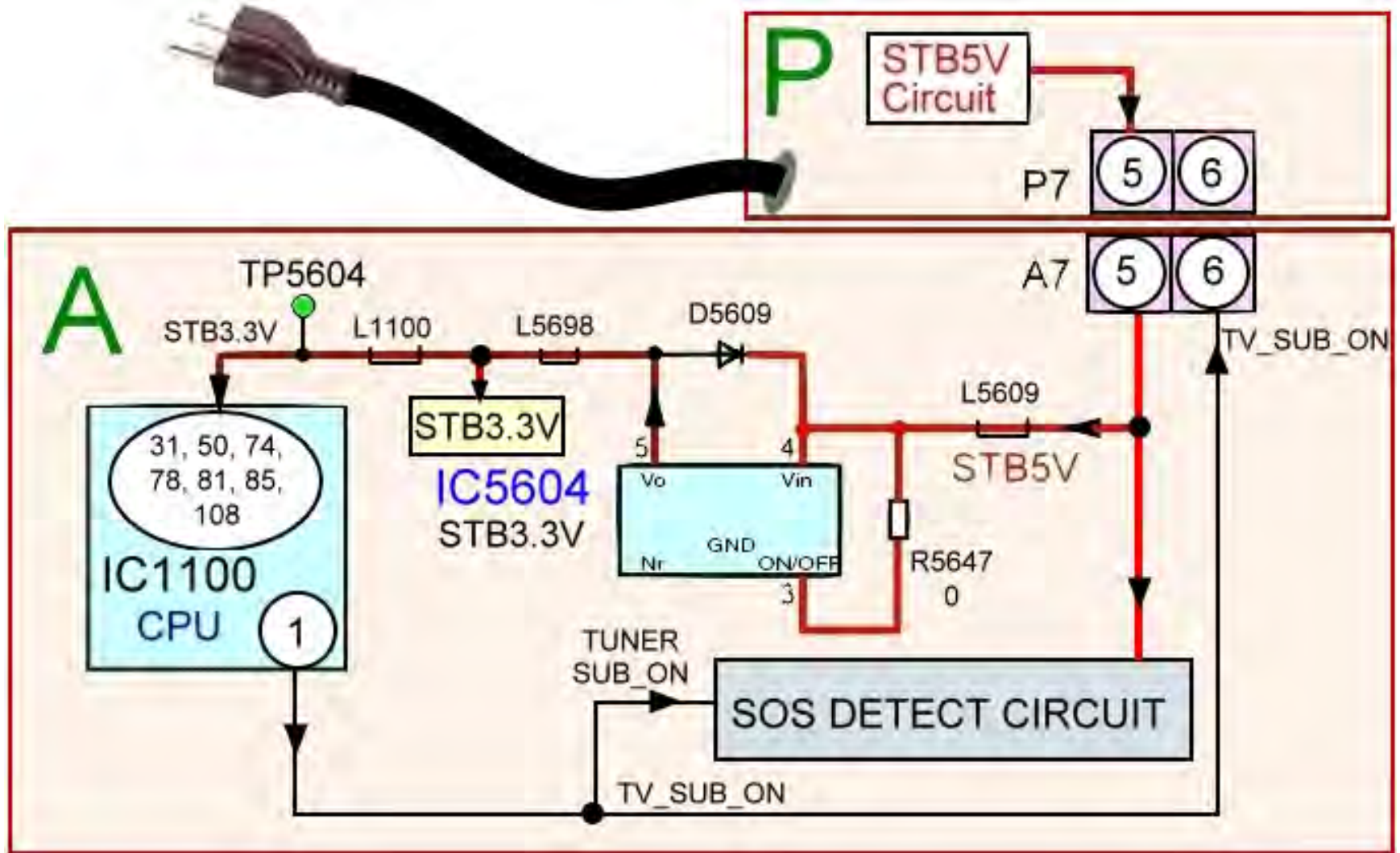

# Main CPU VCC Supply (A Board)

On the A board, the STB5V is applied to pins 3 and 4 of the 3.3V regulator (IC5604). Pin 4 is the voltage input to the IC and pin 3 is the ON/OFF command. The STB5V at pin 3 allows pin 5 to output 3.3V. The 3.3V from IC5604 is then applied to pins 31, 50, 74, 78, 81, 85, and 100 of the CPU (IC1100). This turns on the main CPU (IC1100) and a high command (TV\_SUB\_ON/TUNER\_SUB\_ON) is output on pin 1.

This command splits in 2 (TUNER\_SUB\_ON and TV\_SUB\_ON).

The TUNER\_SUB\_ON command together with the STB5V is applied to the “SOS detect circuit” to monitor the sub voltages generated in the A board.

The TV\_SUB\_ON command is applied to the power supply board (P board) to create the F+15V.

# TV\_SUB\_ON/TUNER\_SUB\_ON

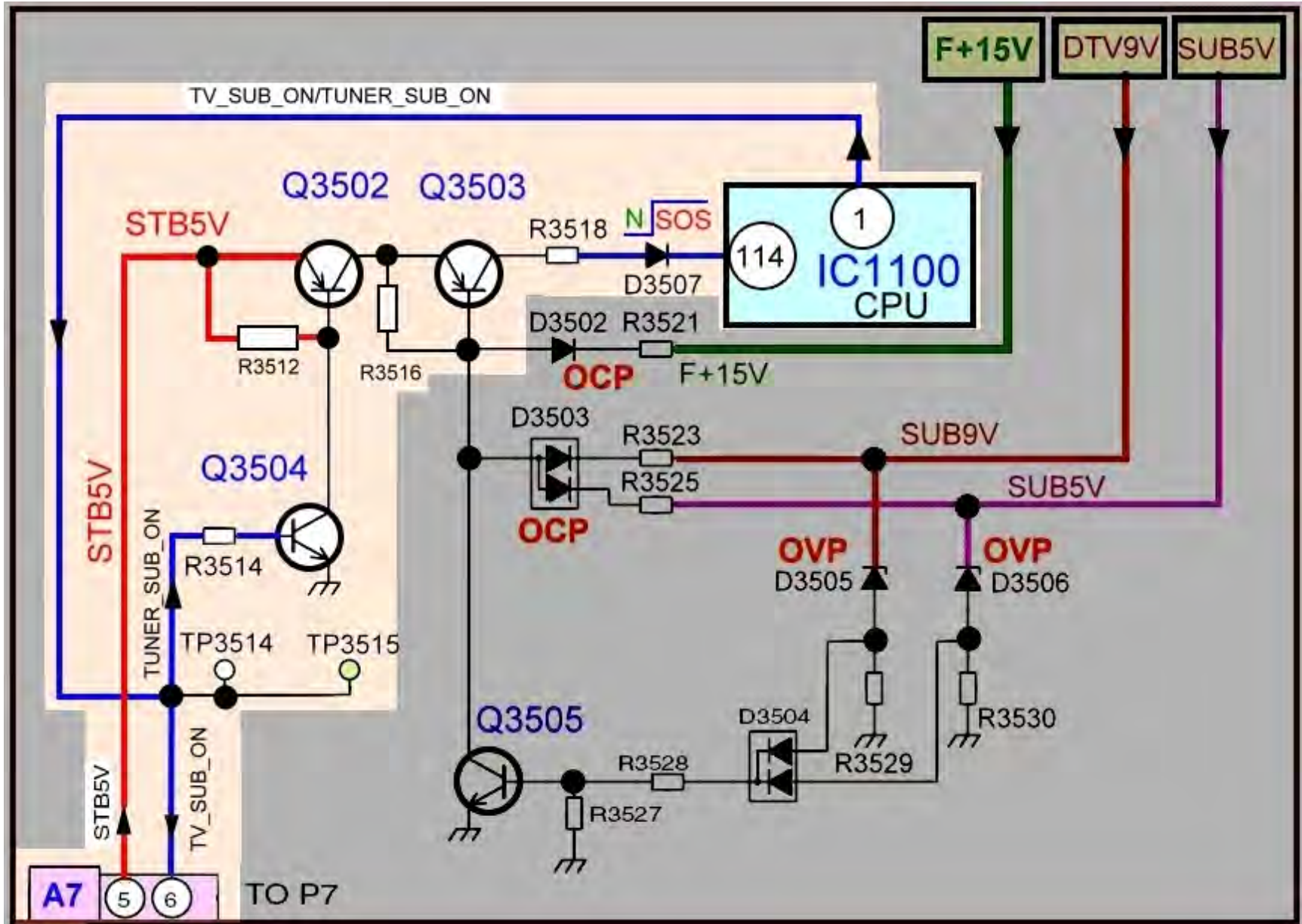

# TV\_SUB\_ON/TUNER\_SUB\_ON

The STB 5V at pin 5 of connector A7 and the TV SUB ON command at pin 6 are used to activate the PA SOS detect circuit on the A board. This circuit monitors the F+15V, DT9V, and SUB5V for abnormality. Under normal operation, the TUNER\_SUB\_ON voltage from pin 1 of the main CPU (IC1101) turns on Q3504. When Q3504 is on, a low is applied to the base of Q3502 turning it on. When Q3502 is on, 5V is applied to the emitter and base of Q3503. The transistor remains off until a short circuit or excessive voltage is developed in the supply lines connected to its base. When Q3503 is off, a low is output to pin 114 of IC1100.

# TV\_SUB\_ON (F\_STB\_ON)

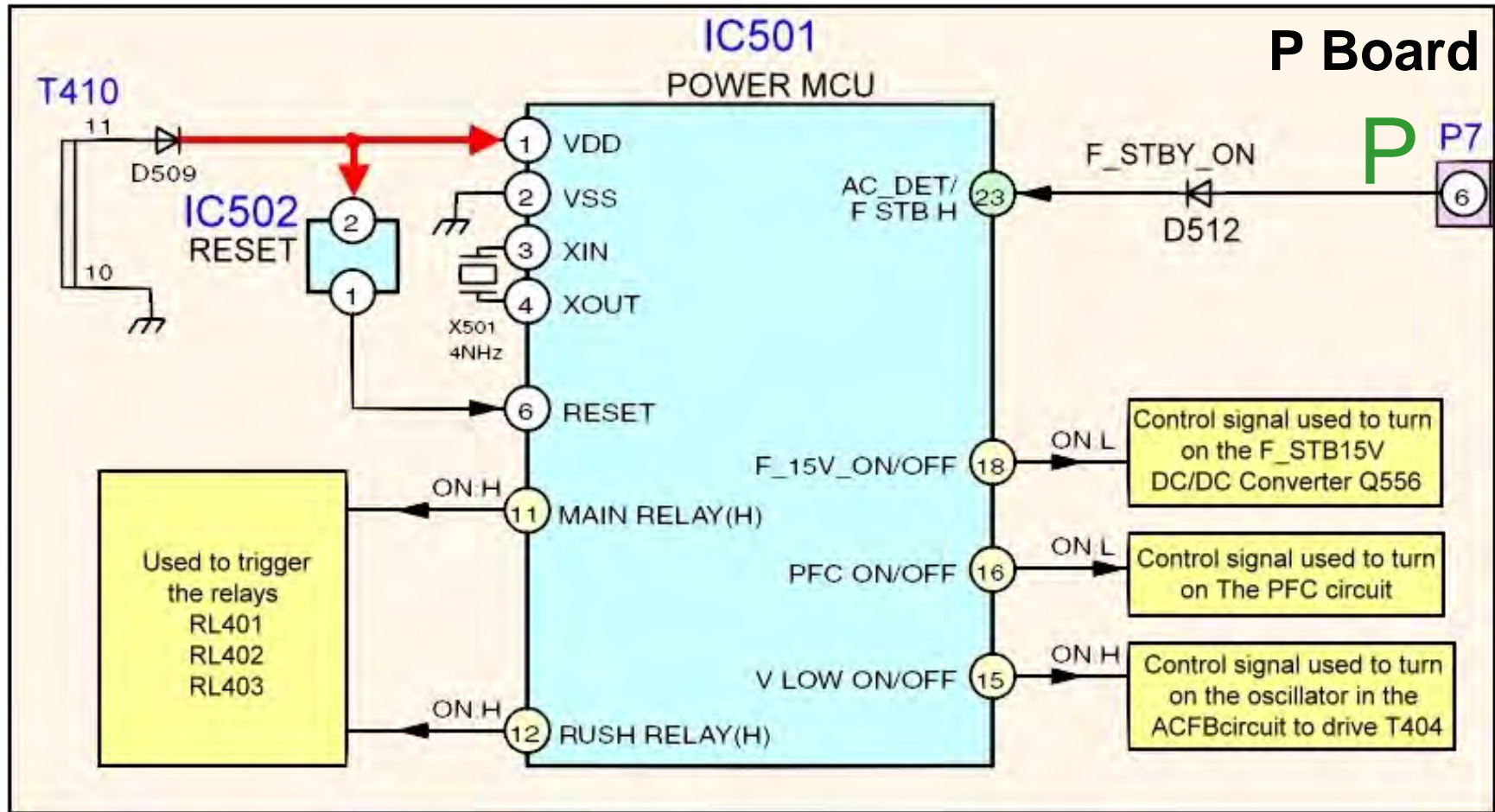



# TV\_SUB\_ON (F\_STB\_ON)

The F-STB-ON voltage (3.2V) from pin 6 of connector P7 is applied to pin 23 of the Power CPU (IC501) on the P board. IC501 sends out commands to first turn on the primary circuit of the power supply, and then the circuit that allows the F\_STB15V to develop.

1. The relay commands (high) from pins 11 and 12 of IC501 are used to trigger the relays RL402 and RL403.
2. A low from pin 16 of IC501 is used to turn on the power factor control IC (IC406) to generate the 395V DC.
3. A high from pin 15 of IC501 is used to turn on the V-low power control IC (IC520) to turn on the oscillator in the “Active Clamp Full Bridge System” circuit.
4. A low from pin 18 of IC501 is used to turn on the F\_STB15V DC/DC converter Q556.

# TV\_SUB\_ON (Relay Drive Circuit)

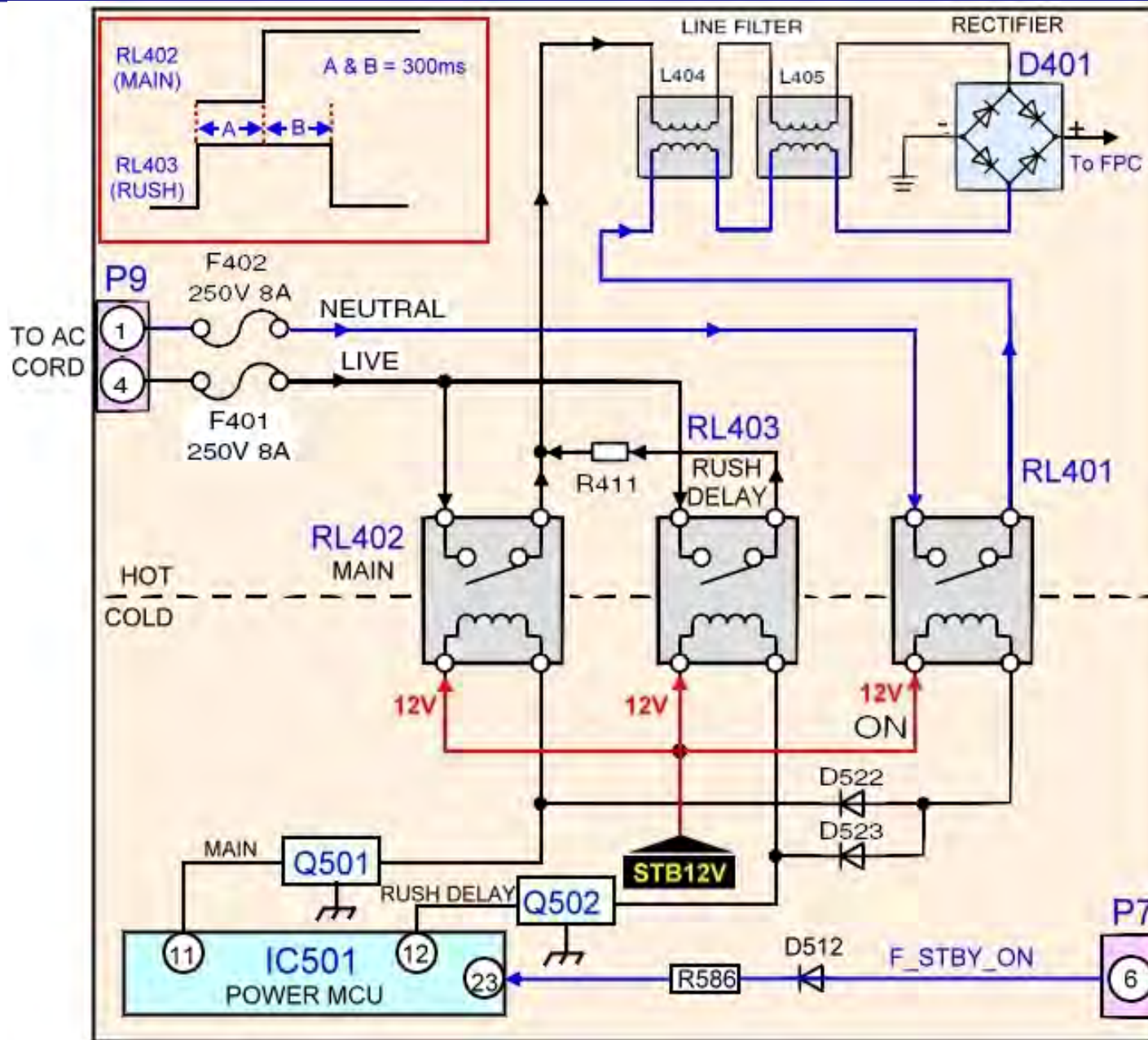

# TV\_SUB\_ON (Relay Drive Circuit)

The F\_STBY\_ON voltage (3.2V) from pin 6 of connector P7 is applied to pin 23 of the power MCU (IC501) on the P board. When pin 23 goes “high”, pin 12 goes “high” turning on Q502 to trigger the inrush relay RL403.

Approximately 300ms later, pin 11 also goes “high” turning on Q501 to trigger the main relay RL402.

300ms later, pin 12 goes “low” allowing for only the main relay RL402 to remain on.

RL401 is triggered whenever RL402 or RL403 are triggered.

AC voltage flows through the relays’ contact, the line filter and the bridge rectifier D401 for conversion into DC.





# ACFB (Active Clamp Full Bridge Switching) Circuit

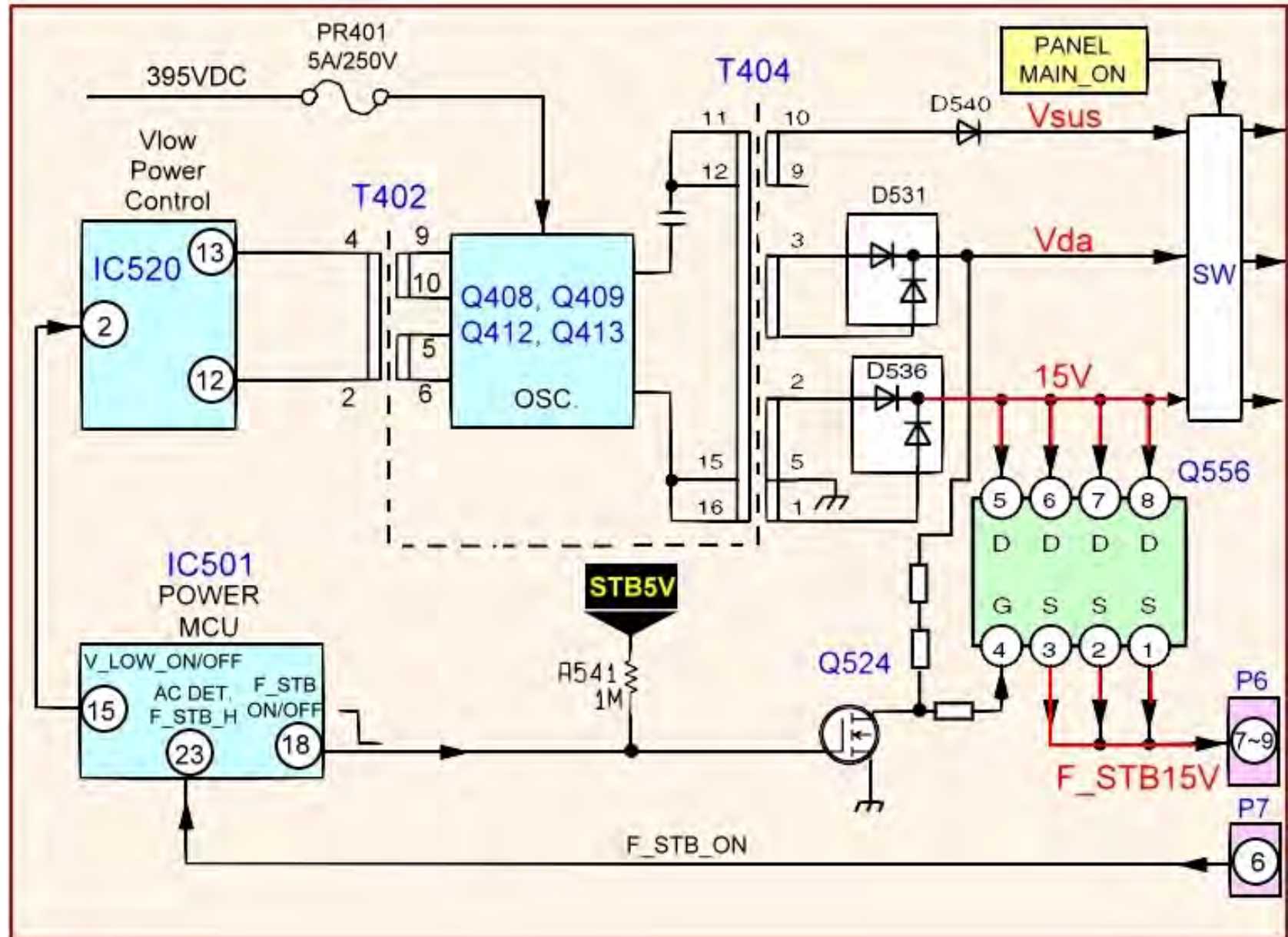



# ACFB (Active Clamp Full Bridge Switching) Circuit

The PFC 395VDC is applied to the switching circuit (Q408, Q409, Q412, and Q413). The operation of this switching circuit is controlled by the transformer T402 which is driven by the V-low power control IC, IC520.

1. A “high” from pin 15 of IC501 is used to turn on the power control IC (IC520) to energize the primary of transformer T402 and allow the switching circuit to drive transformer T404.
2. The secondary circuit of transformer T404 outputs the  $V_{sus}$ ,  $V_{da}$ , and 15V voltage sources.
3. The 15V is applied to the DC-DC converter (Q556). The output of Q556 is controlled by pin 4.
4. Pin 18 goes low to turn off Q524. When Q524 is off, 22V is applied to pin 4 of Q556 turning it on. At this time pins 1, 2, and 3 of Q556 output the F\_STB15V.
5. The F\_STB15V is applied to pins 7, 8, and 9 of connector P6.

# MAIN/SUB Voltages

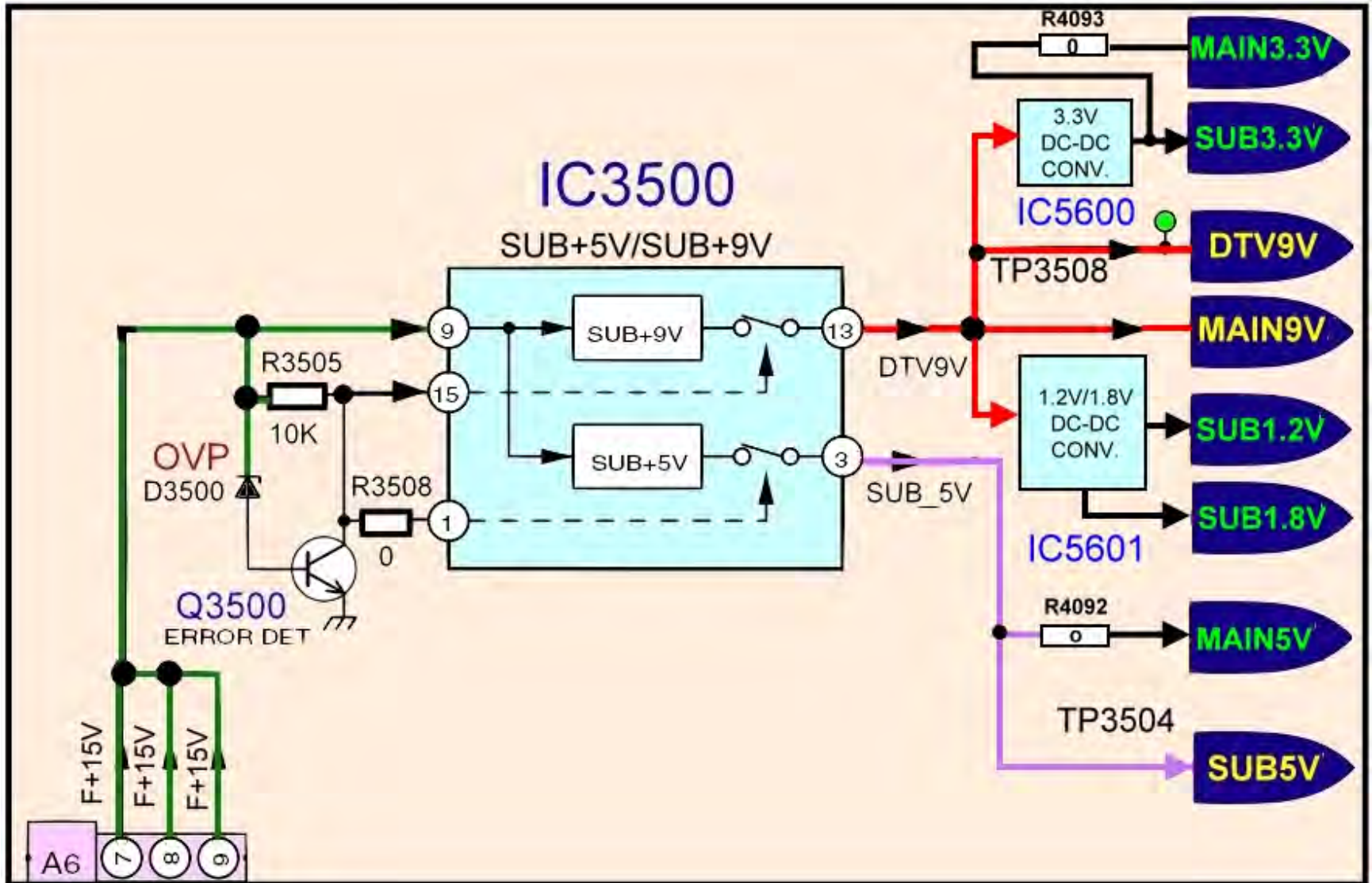

# MAIN/SUB Voltages

The F+15V from the power supply is applied to pins 6, 7, and 8 of connector A6 on the A board. The 15V is applied to the voltage input pin (pin 9) of the “SUB+5V/SUB+9V” dual regulator IC3500. The 15V is also used to keep pin 1 and pin 15 high.

Pin 1 and pin 15 are the “ON/OFF” pins. When pin 1 is high, pin 3 outputs 5V. When pin 15 is high, pin 13 outputs 9V.

D3500 monitors the 15V line for “OVER VOLTAGE” condition. If the 15V becomes excessive, D3500 conducts to turn on Q3500. When Q3500 is on, pin1 and pin 15 go low to disable IC3500.

The 9V from pin 13 of IC3500 is applied to the 3.3V DC-DC converter (IC5600) to generate the SUB3.3V.

The 9V is also applied to the 1.2V/1.8V DC-DC converter (IC5601) to generate the SUB1.2V and the SUB1.8V

# F+15V, DTV9V, SUB5V SOS Detect Circuit

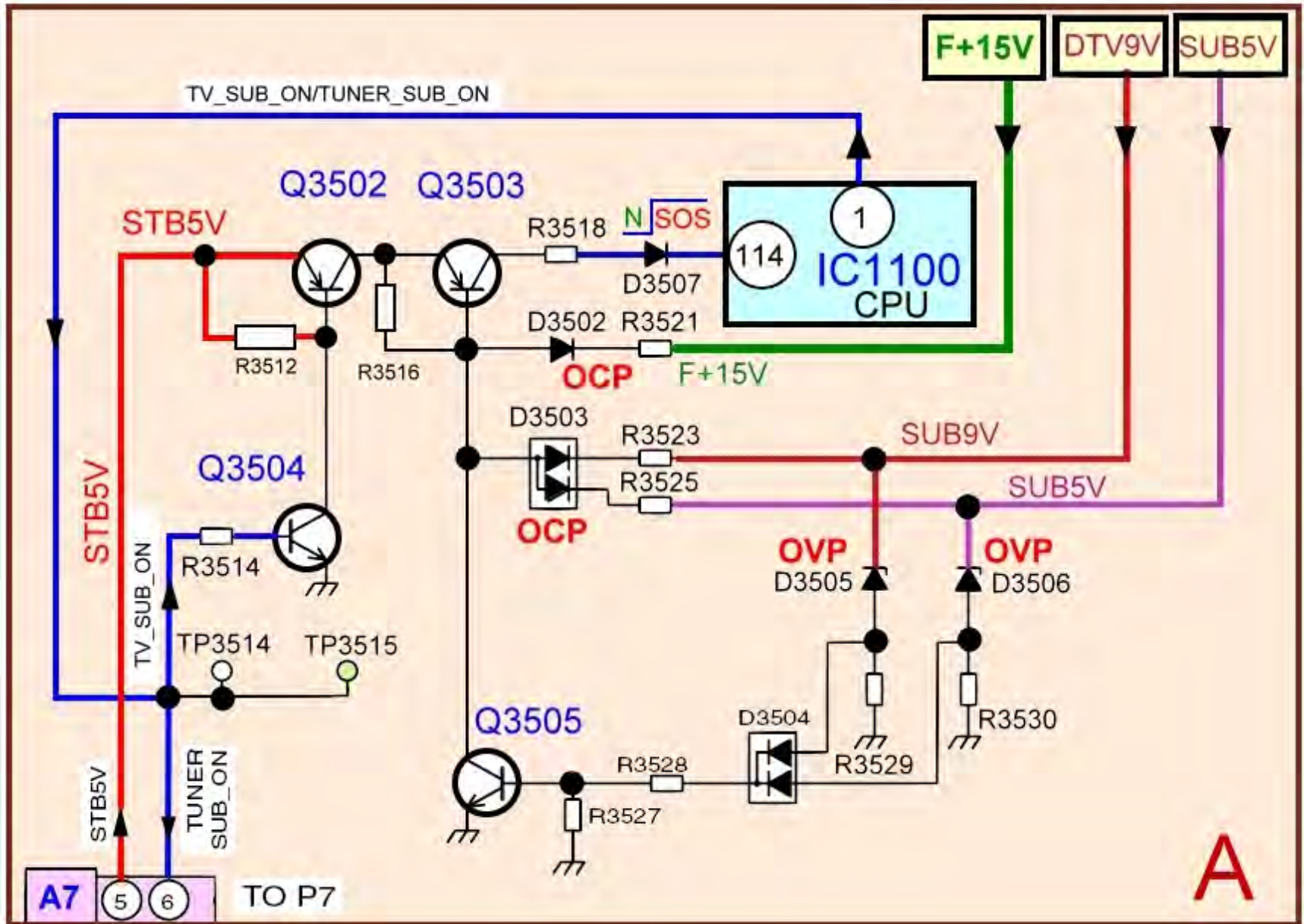

# F+15V, DTV9V, SUB5V SOS Detect Circuit

The F+15V, DTV9V, and SUB5V are monitored for over-voltage and over-current conditions by the SOS circuit on the A board.

Under normal condition, pin 114 of the main CPU (IC1100) is low. When a short circuit or an over-voltage condition occurs, the SOS detect circuit is triggered causing pin 114 to go high. When pin 114 goes high, the TV shuts down and the power LED blinks 10 times.

When the F+STB15V line is shorted, the base of Q3503 goes low turning it on. When Q3503 is on, a high is applied to pin 114 of IC1100 triggering the shutdown operation.

The same will happen if a short circuit develops in the DTV9V line and the SUB5V line.

The transistor Q3505 monitors the SUB5V and the DTV9V lines. If any of these supply voltages becomes excessive, the inline zener diode (D3505 or D3506) goes into conduction and turns on transistor Q3505. As a result, a voltage drop appears at the base of Q3503, causing it to turn on and output a high to pin 114 of the MPU, IC1100. The MPU shuts down the unit.



# Power On Operation

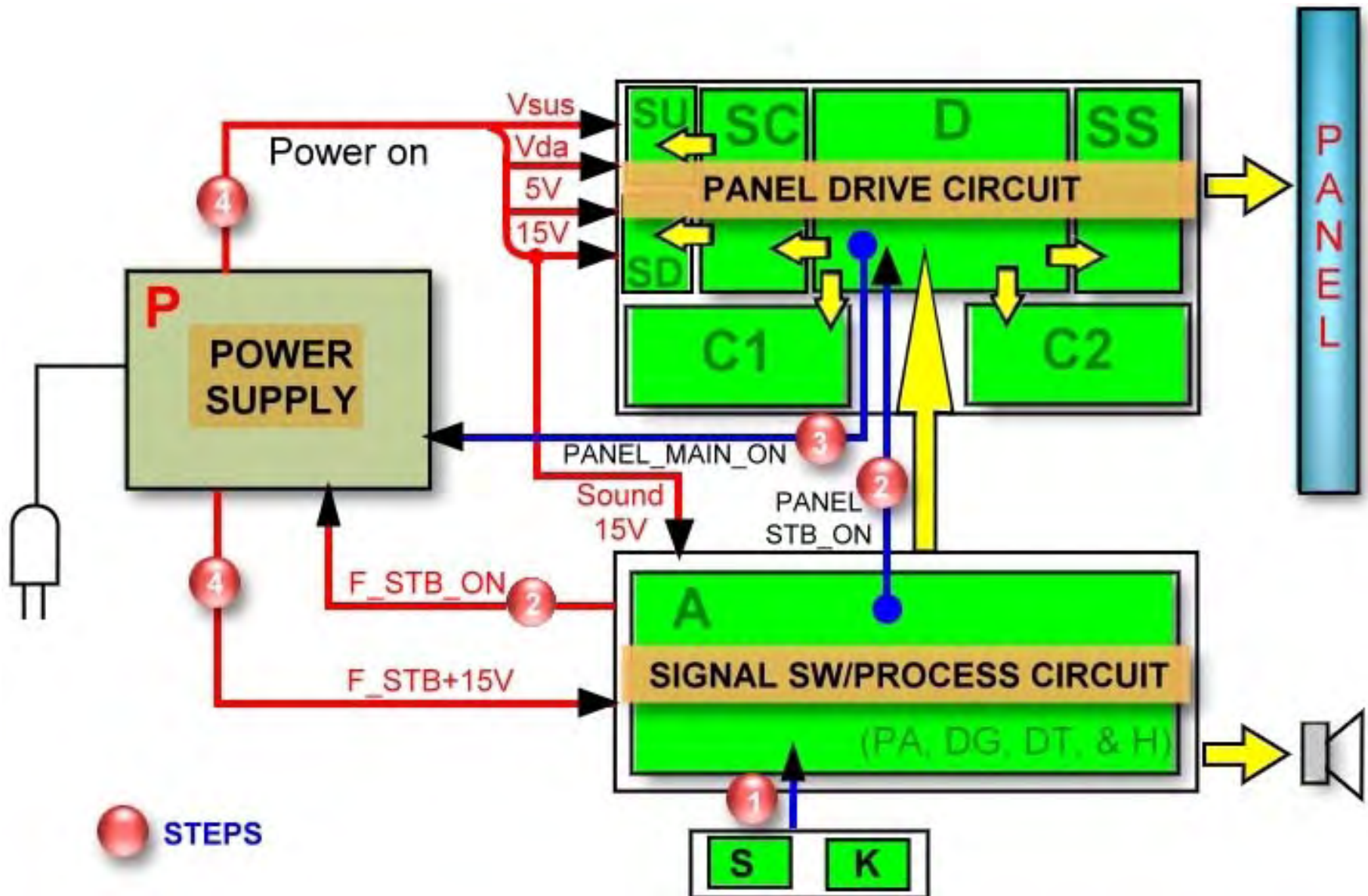

# Power On Operation

The power command from the power switch on the S board or the remote control receiver on the K board is provided to the CPU in the A board. The CPU on the A board outputs the "PANEL\_STB\_ON" command and the "F\_STB\_ON" command. The "PANEL\_STB\_ON" is provided to the D board to turn on the STB3.3V regulator. The output voltage is applied to the CPU in the D board. The "F\_STB\_ON" command is provided to the power supply to develop the F\_STB+15V.

When the CPU on the D board is energized, it outputs the "PANEL\_MAIN\_ON" command to the power supply. This command turns on the power supply circuit that outputs the Vsus, Vda, 15V, and 5V.

# Power-On (1)

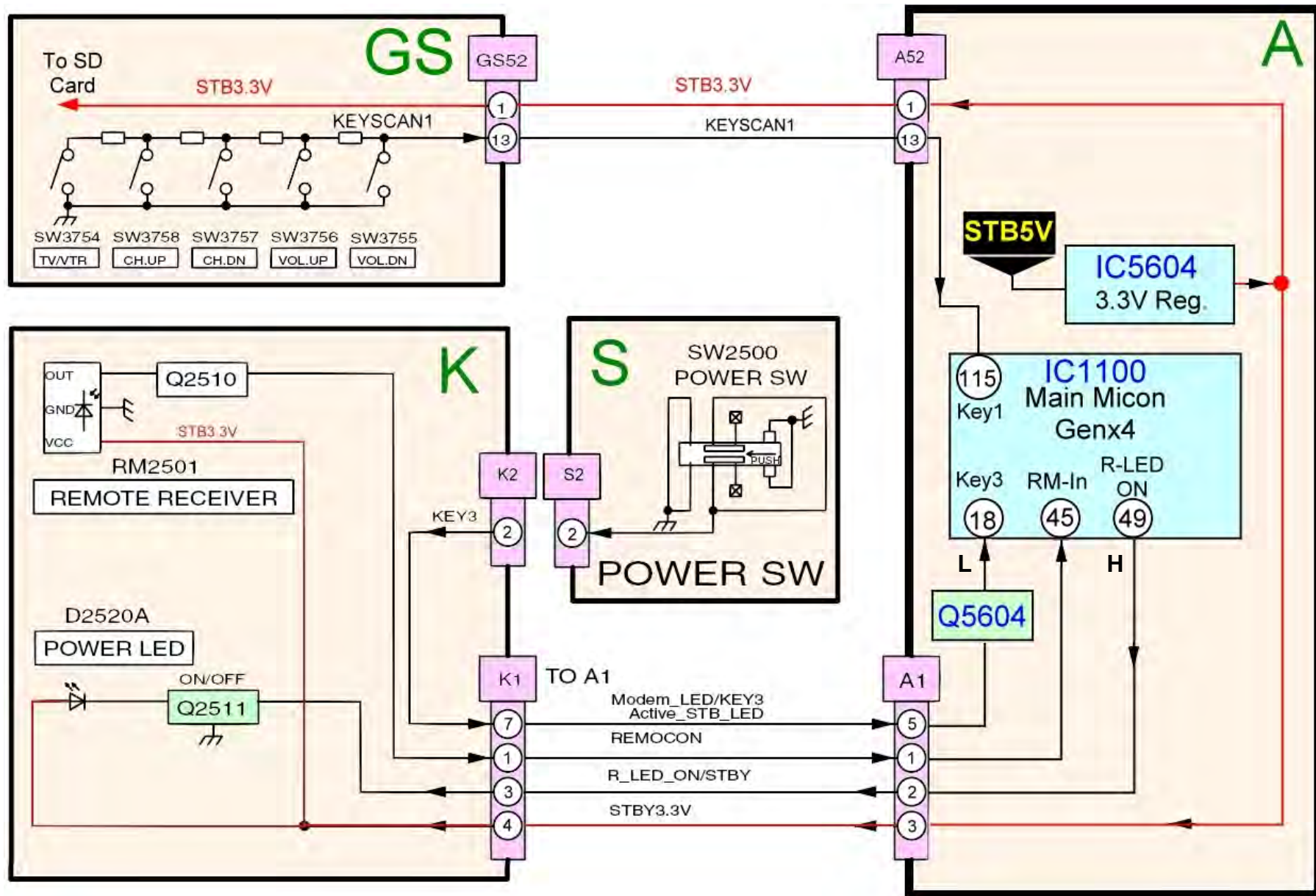

# Power-On (1)

When the unit is turned on using the power button on the front of the TV, the momentary connection of the power switch to ground supplies a low to the base of Q5604 (DG board) to turn it on. Q5604 outputs a low to the key input line (pin 18) of the CPU IC1100 on the A board.

The R/C receiver receives the power on command of the remote control and outputs the IR data to the amplifier Q2510 of the A board. The data is amplified and output to pin 45 of the MPU, IC1100.

A high from pin 49 of IC1100 enters the base of Q2511 to turn it on. As a result the cathode of D2520A goes low causing the illumination of the power LED.

# Power On (2)

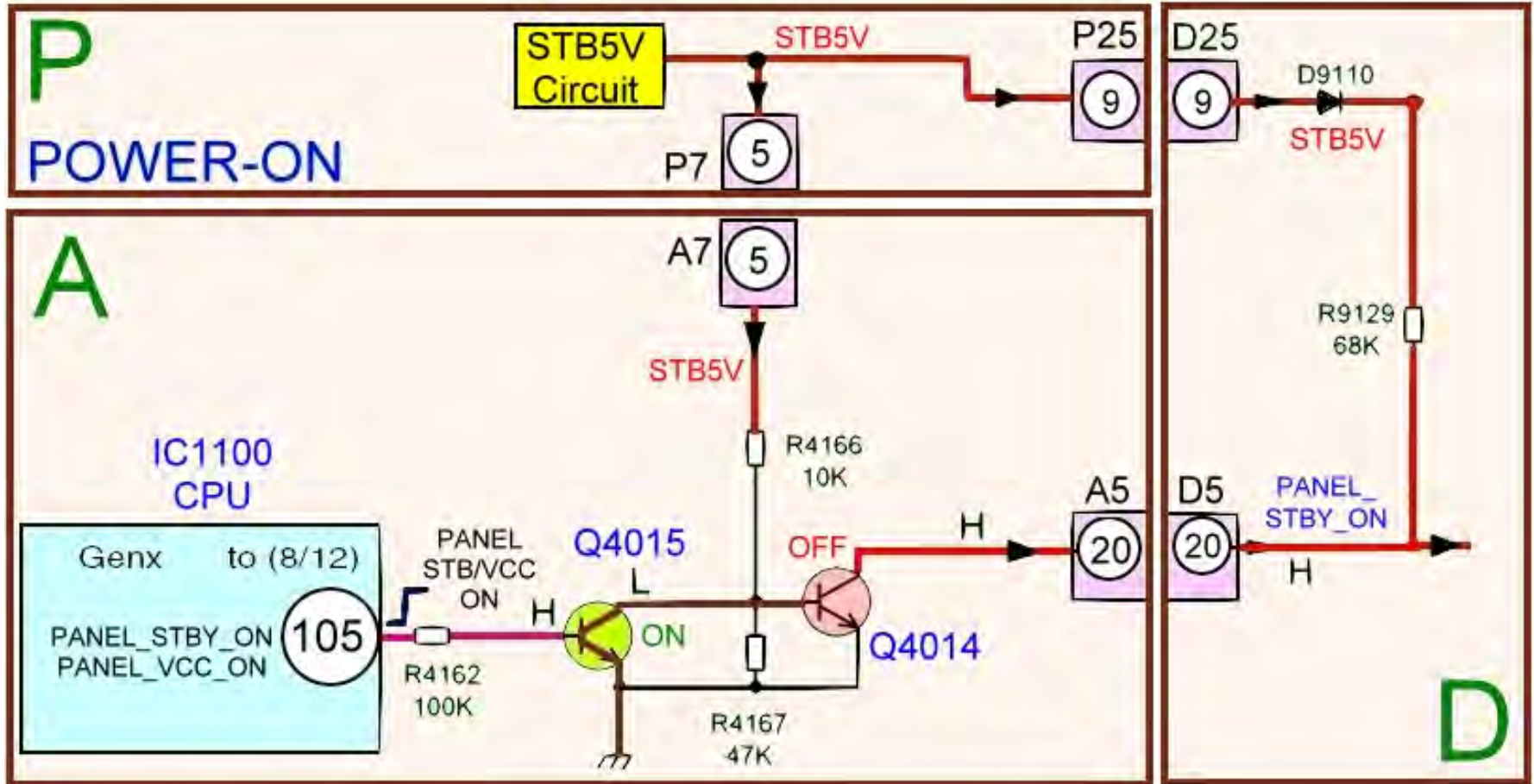

Upon receiving the power on command , the “PANEL STB/VCC ON” pin of the main MPU (IC1100) outputs 2.5V to the base of Q4015, turning it on. Q4015 outputs a low to turn off Q4014 allowing pin 20 of the connector A5/D5 to go high.



# Power On (3)

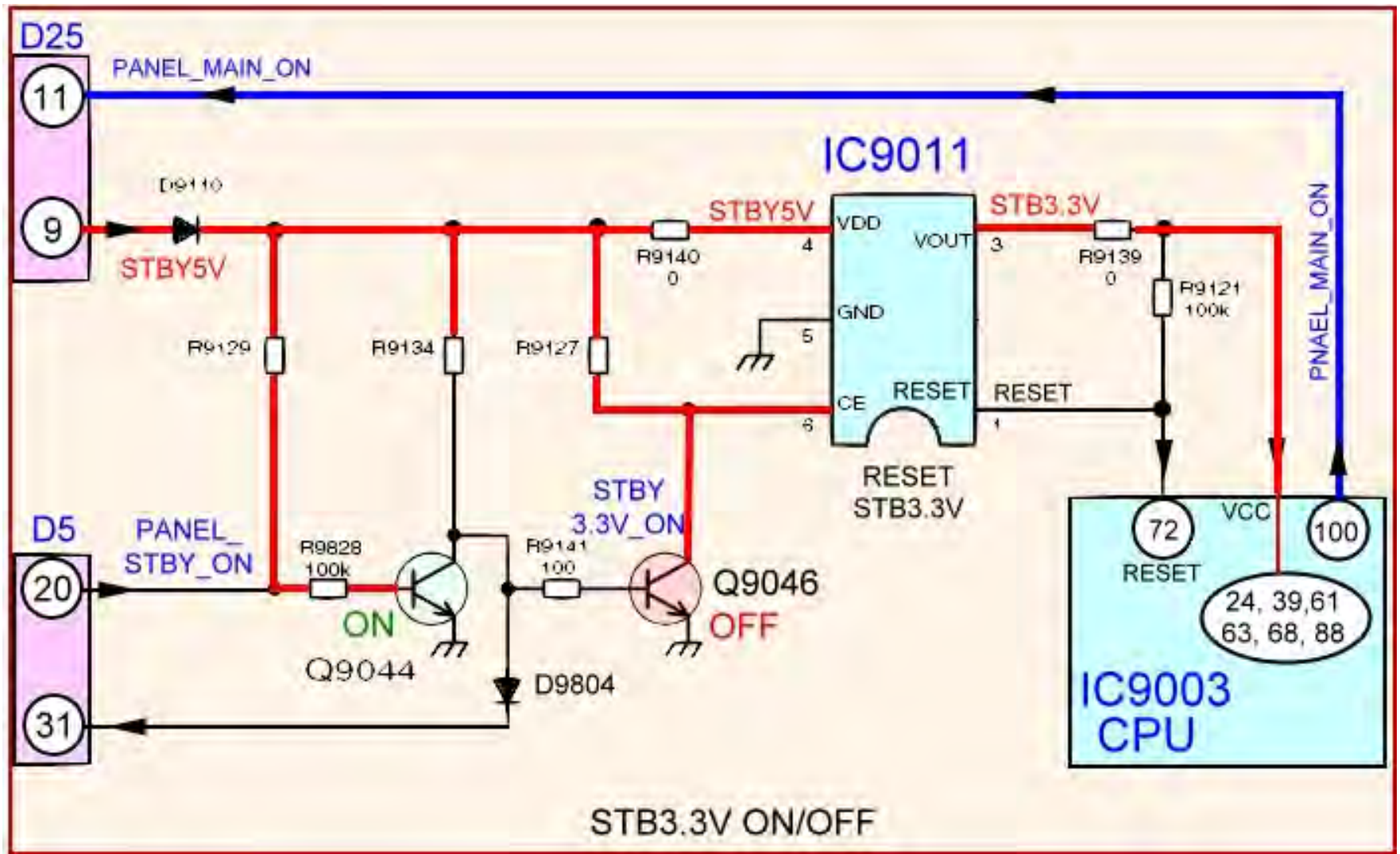

# Power On (3)

The STBY5V from the power supply board is applied to pin 4 of the regulator, IC9011. During Standby operation, the regulator does not operate due pin 6 being low.

Upon receiving the power on command , the “PANEL STB ON” high from pin 20 of connector D5 is applied to the base of Q9044 on the D board, turning it on. Q9044 outputs a low to turn off Q9046. When pin 6 goes high, IC9011 outputs the reset command at pin 1 and the STB3.3V at pin 3.

The STB3.3V is applied to the VCC pins of the CPU IC9003 (pins 24, 39, 61, 63, 68, and 88). The CPU then outputs a high (3.2V) at pin 100. The 3.2V is directed to the power supply via pin 11 of connector D25/P25.

# Power On (Summary)

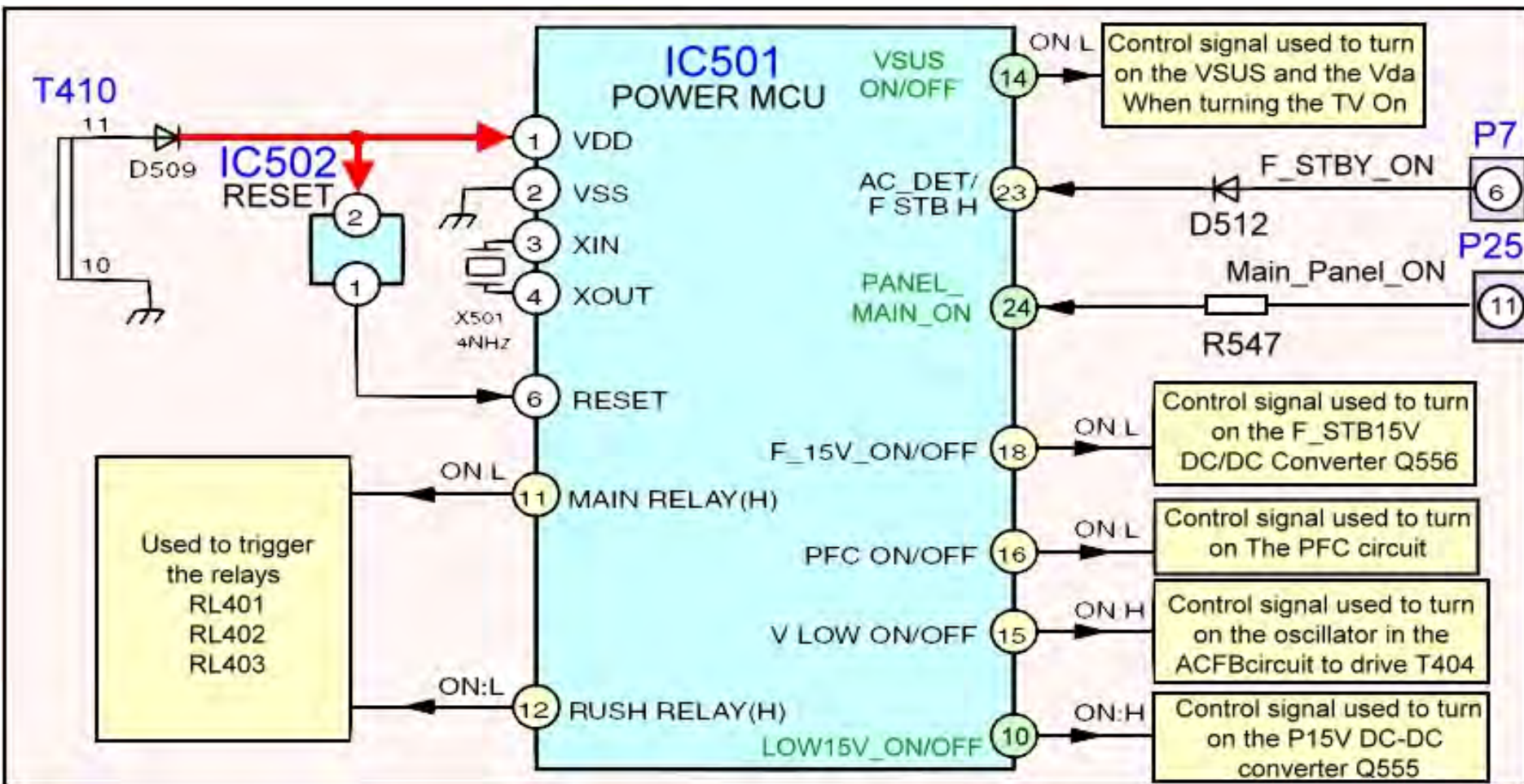

When the power is turned on, the "PANEL MAIN ON" command and the "F STB ON" command are applied to the power MCU (IC501). The complete standby operation is repeated when the "F STB ON" command from the A board is applied to pin 23. When the (3.2V) "PANEL MAIN ON" command from the D board is applied to pin 24 of IC501, pin 10 goes high and pin 14 goes low. The high from pin 10 turns on the 15V DC-DC converter (Q555) to output the P15V. When pin 14 goes low, the Vsus switching circuit is turned on to allow for Vsus and Vda to be output.



# P15V/P5V Circuit

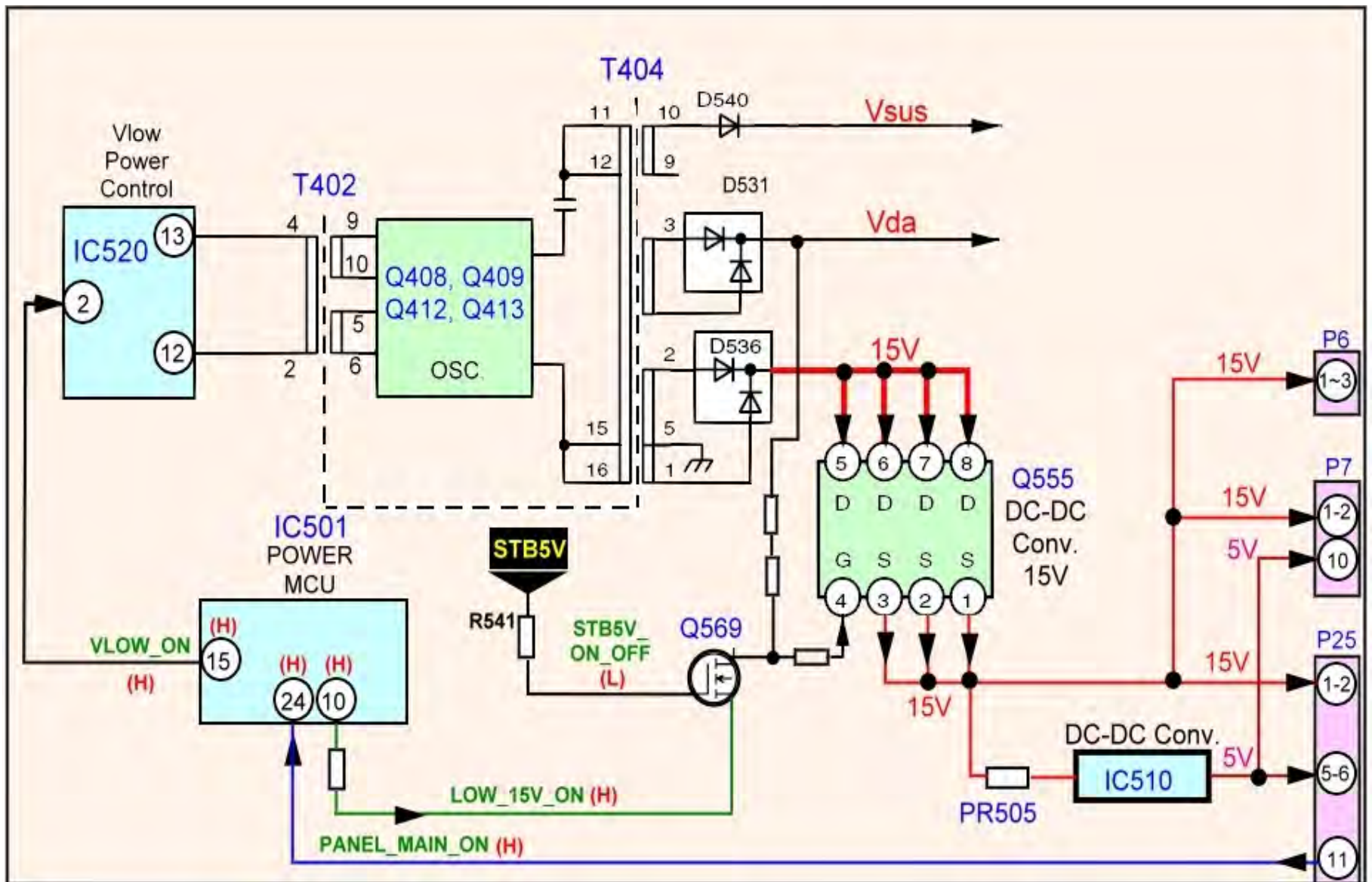

# P15V/P5V Circuit

The P15V is generated when the power is turned on. The high (3.2V) “Panel Main On” command from the D board is applied to pin 24 of the Power MCU (IC501) on the Power Supply board. When IC501 receives this command on pin 24 (3.2V), pin 10 goes high (4.8V).

When the power on command is received, the F\_STB\_ON command (3.2V) is applied to pin 23 of IC501. When pin 23 goes high, just like during standby, the relays are closed, the PFC circuit is on, and pin 15 goes high to turn on the low voltage power control (IC520) to drive the oscillator circuit (Q408, Q409, Q412, and Q413).

When this happens, voltages are developed by the secondary circuit.

The rectified 15V from T404, is applied to the DC-DC converter (Q555).

The output of Q555 is controlled by the voltage on pin 4.

The high from pin 10 changes the bias of Q569 to provide 22V to pin 4 of Q555, turning it on. When Q555 is on, 15V is output on pins 1, 2, and 3. This voltage is applied to the 5V DC-DC converter (IC510) to output the P5V.



# Vsus/Vda Circuit

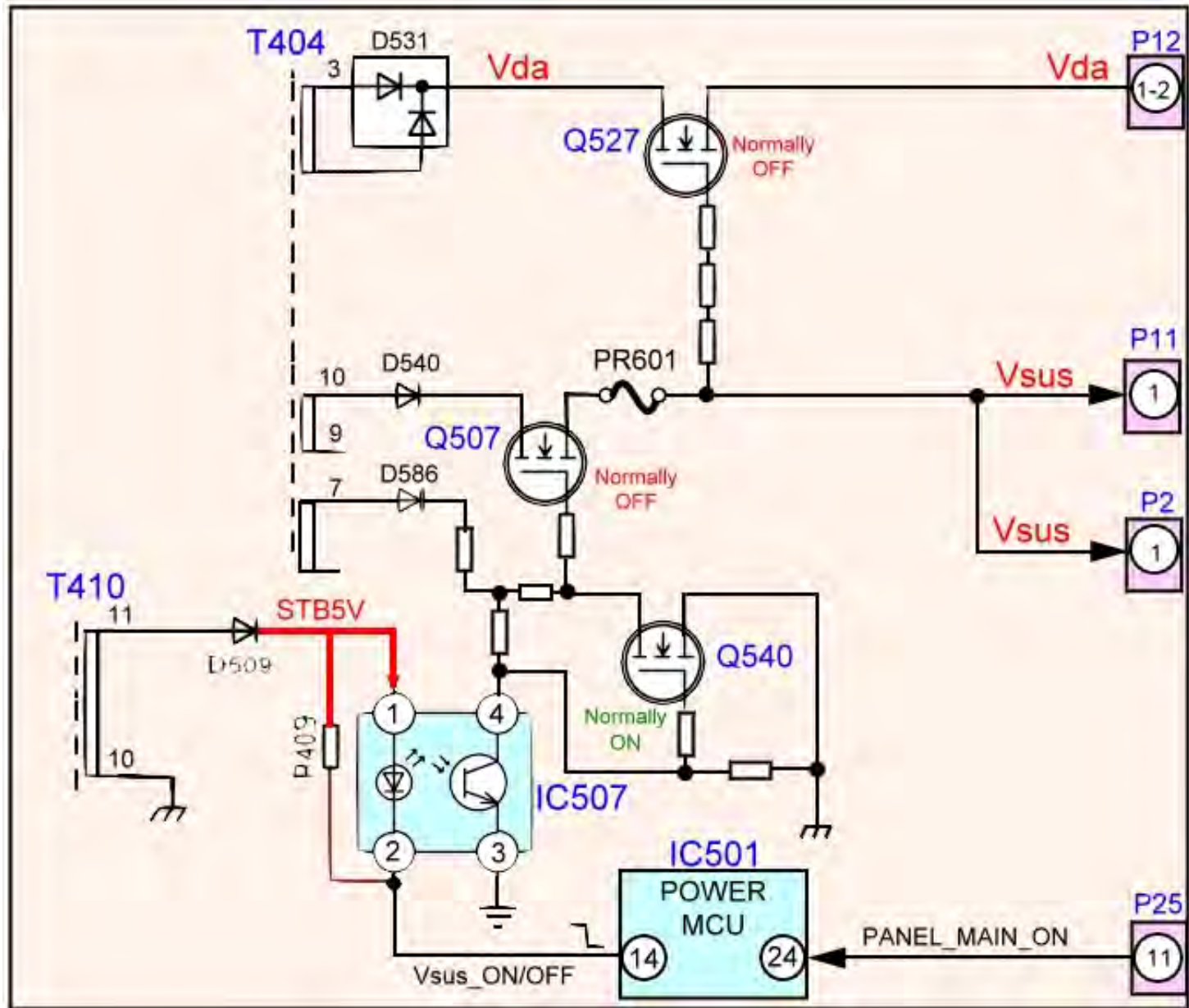

# Vsus/Vda Circuit

The 3.2V from pin 11 of connector P25 is applied to the PANEL\_MAIN\_ON pin (24) of the POWER CPU (IC501). When pin 24 goes high, pin 14 goes low to provide the ground path to turn on the LED within the photo-coupler IC507. The light from the LED turns on the phototransistor within the photo-coupler and its collector (pin 4) goes low to turn off Q540. When Q540 is off, the DC voltage from the rectifier D586 is applied to the gate of Q507 turning it on. Q507 outputs the VSUS voltage. The VSUS voltage is also used to turn on Q527 to output the VDA.

# Troubleshooting (No Power/Dead Unit) Part 1

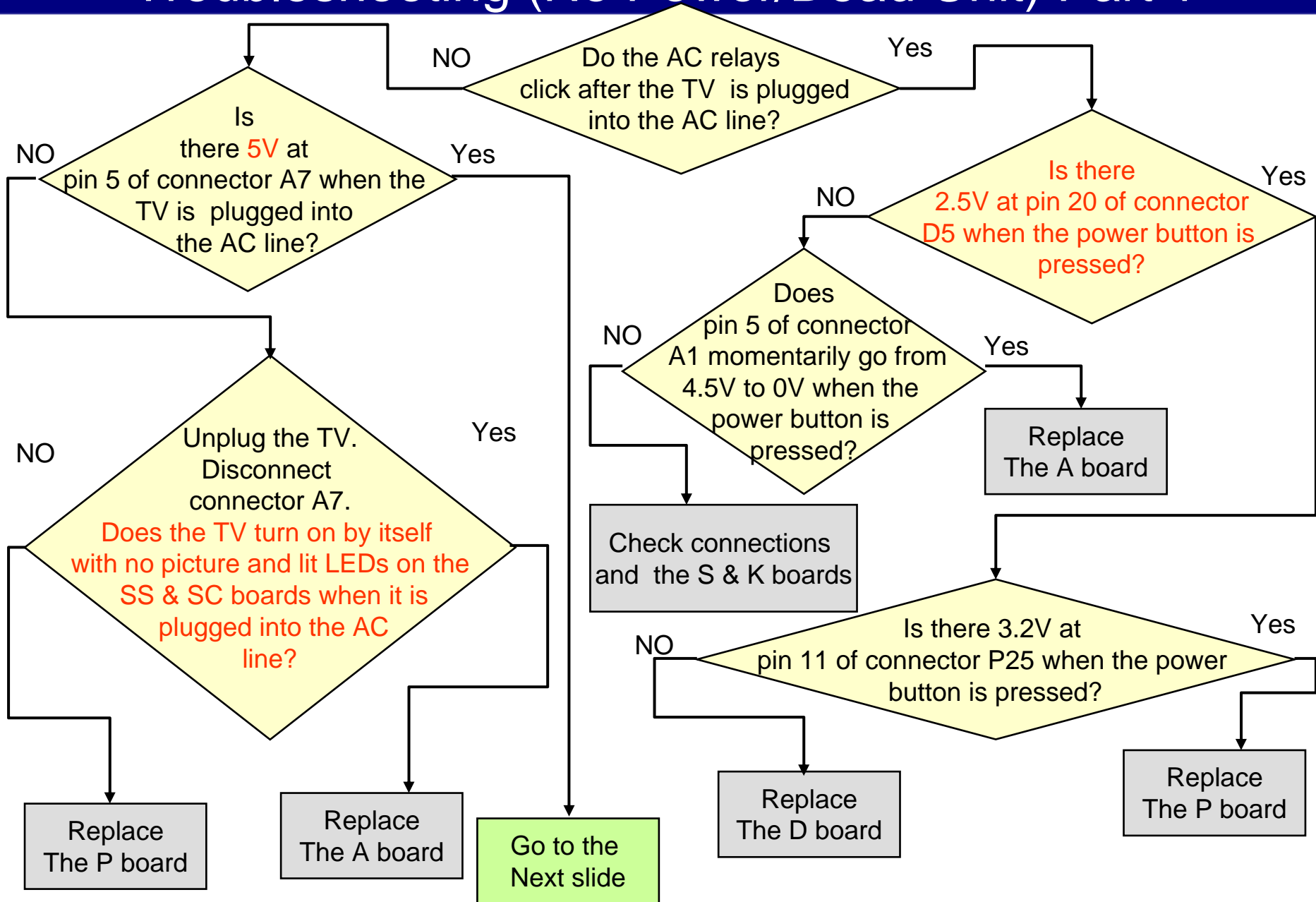

# Troubleshooting (No Power/Dead Unit) Part 2

Continue from Previous slide

NO

Is there 3.3V at pin 6 of connector P7 when the TV is plugged into the AC line?

Yes

Replace The P board

NO

Disconnect connector A1. Do the AC relays click after the TV is plugged into the AC line?

Yes

If cable between connectors K1 and A1 is OK, Replace the K board

NO

Reconnect A1 and Disconnect connector A52. Do the AC relays click after the TV is plugged into the AC line?

Yes

If cable between connectors GS52 and A52 is OK, Replace the GS board

Replace The A board

## *Shutdown Circuits*





# SOS Circuit Overview

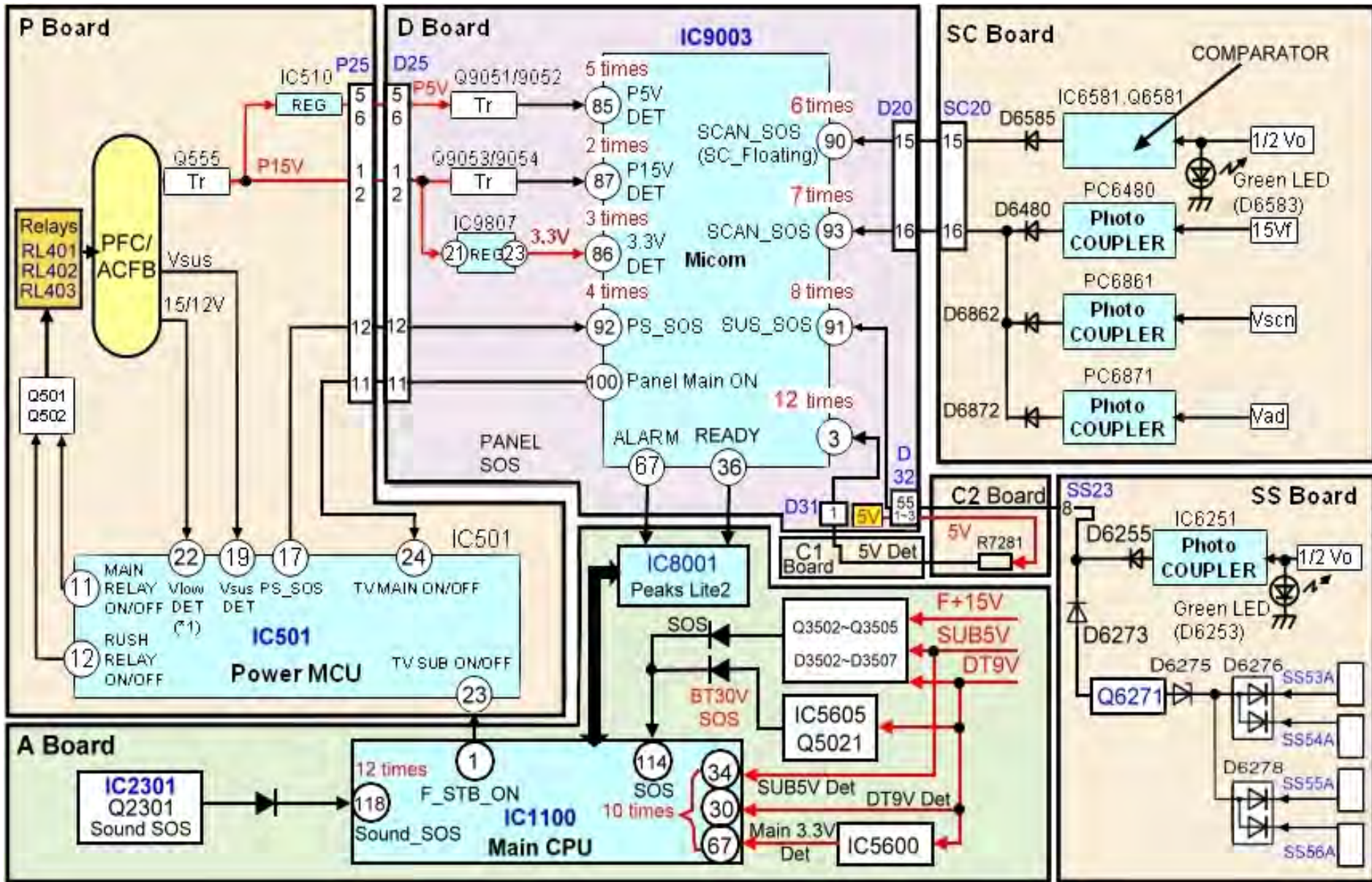

# SOS Circuit Overview

Protection circuits are incorporated in the unit to prevent the failure of a single circuit or component from creating catastrophic damage.

**1 Blink SOS:** This shutdown operation is usually caused by a lack of communication between the A and the D boards.

**1 Blink SOS:** This shutdown operation may be caused by the improper connection of a SS board connector to the panel.

**2 Blinks SOS:** Pin 87 of the MPU IC9003 monitors the 15V line. During normal operation, the transistors Q9053 and Q9054 output a high to pin 87. If the 15V line is missing or shorted, a low is provided to pin 87. As a result, the unit shuts down and the power LED blinks 2 times.

**3 Blinks SOS:** IC9807 is a 3.3V regulator located on the D board. Its output is monitored by IC9003. If the 3.3V is not present at pin 86, the MPU shuts down the unit. The power LED blinks 3 times.

**5 Blinks SOS:** Pin 85 of the MPU IC9003 monitors the 5V line. During normal operation, the transistors Q9051 and Q9052 output a high to pin 85. If the 5V line is missing or shorted, a low is provided to pin 85. As a result, the unit shuts down and the power LED blinks 5 times.

**6 Blinks SOS:** Pin 90 of the MPU IC9003 monitors the status of the SC board. During normal operation, the transistor Q6581 and IC6581 output a low to pin 90. If the SC board becomes defective, a high is provided to pin 90. As a result, the unit shuts down and the power LED blinks 6 times.=

# SOS Circuit Overview

**6 Blinks SOS:** 6 blinks of the power LED may also be obtained from pin 3 of IC9003, the DRV\_RESET input. The D board provides the 5V source needed to power the C boards. On the C2 board, the 5V is routed back to the D board via connector C20/C10, C11/D31 causing pin 3 of IC9003 to be high. If 5V is not routed back to the D board, pin 3 of IC9003 goes low. The set goes into shutdown mode and the power LED emits 6 blinks.

**7 Blinks SOS:** Pin 93 of the MPU IC9003 monitors the status of the SC, SU, SD board. During normal operation, the photo-coupler PC6480 outputs a low to pin 93. If the SC, SU, or SD board becomes defective, a high is provided to pin 93. As a result, the unit shuts down and the power LED blinks 7 times.

**8 Blinks SOS:** Pin 91 of the MPU IC9003 monitors the status of the SS board. During normal operation, pin 8 of connector SS23 outputs a low to pin 91. If the SS board becomes defective, a high is provided to pin 91. As a result, the unit shuts down and the power LED blinks 8 times.

**10 Blinks SOS:** The SUB5V and DT9V sources created on the A board are monitored by IC1100. If they are not present at pin 30 and 34, the MPU shuts down the unit. The power LED blinks 10 times.

**10 Blinks SOS:** The F\_STB\_15V of the P board, as well as the derived SUB5V and DT9V sources are monitored on the A board for excessive current. If a short circuit is developed in one of the supplied lines, pin 114 of IC1100 receives a high. The SUB5V and DT9V lines are also monitored for excessive voltage. When an over-voltage condition is detected, a high is also output to pin 114 of IC1100. The DT9V is provided to a DC/DC converter to create the BT30V for the tuner. If the BT30V becomes excessive, a high is output to pin 114 of IC1100. A high at pin 114 of IC1100 causes the unit to shutdown and the power LED to blink 10 times.

# SOS Circuit Overview

**10 Blinks SOS:** IC5600 is a 3.3V regulator located on the A board. Its output is monitored by IC1100. If the 3.3V is not present at pin 67, the MPU shuts down the unit. The power LED blinks 10 times.

**12 Blinks SOS:** On the A board, transistor Q2301 monitors the Sound 15V line and the operation of the audio power amplifier IC2301. If the audio output circuit, IC2301, or the 15V lines develops a short to ground, transistor Q2301 goes into conduction and applies a high to pin 118 of the MPU, IC1100, triggering a SOS condition. The power LED blinks 12 times.

**12 Blinks SOS:** We have also discovered that 12 blinks of the power LED may also be caused by a defective SS board. To determine the source of the shutdown, disconnect the connector D5 and connect the unit to the AC source. If the panel turns on and the LEDs of the SS and SC boards stay on, the problem is on the A board. If the panel does not stay on, the problem is likely to be the SS board.



# DRV\_RST SOS

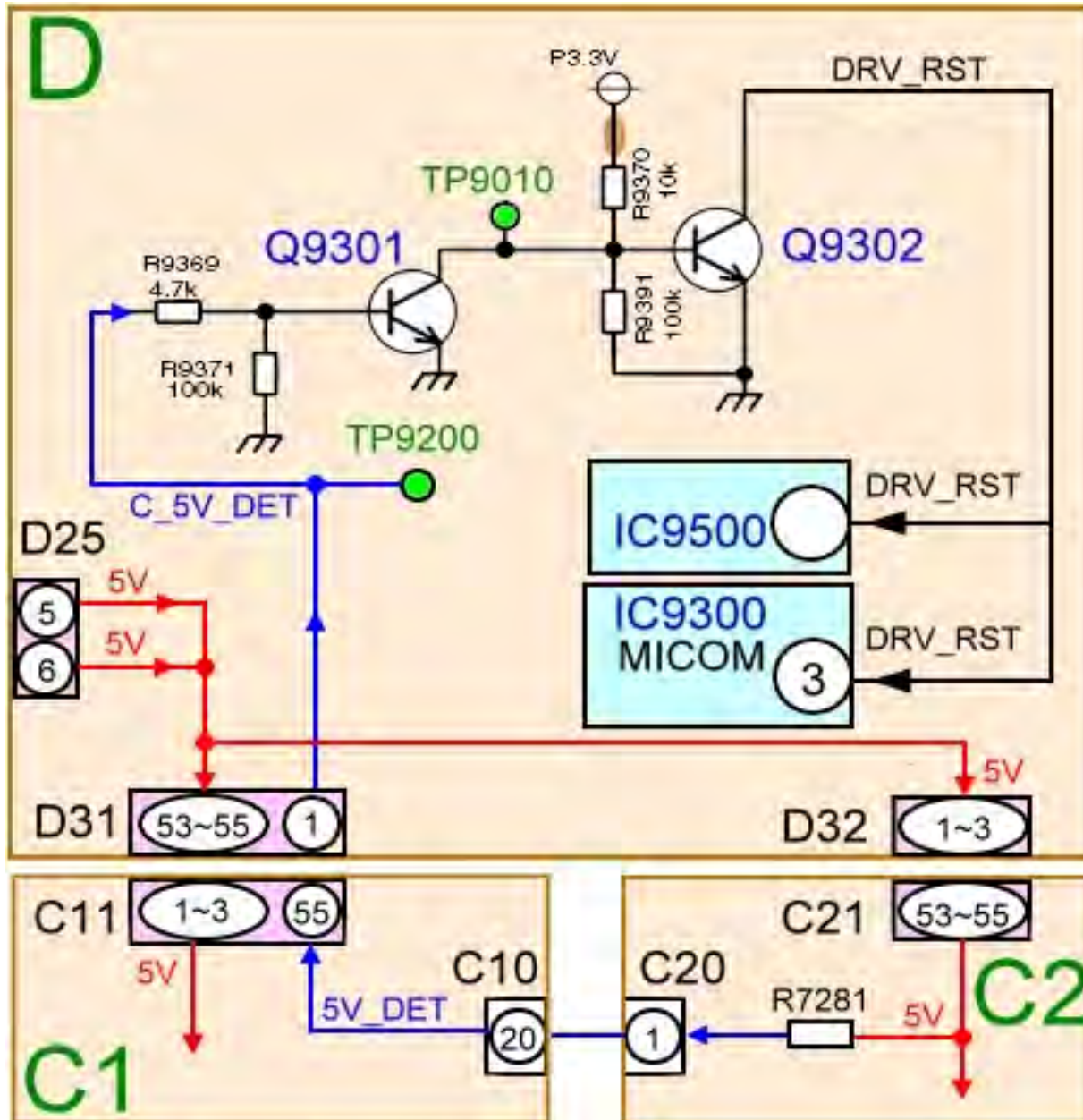

# DRV\_RST SOS

The DRV RST circuit of the D board is used to monitor the physical connection of the D board to the C board. DRV RST input to IC9500 and IC9003 must be high for the unit to operate. The D board provides the 5V source needed to power the C boards. On the C2 board, the 5V is routed back to the D board via connector C20/C10, C11/D31 to activate the 5V SENSE circuit. A voltage divider consisting of R9369 and R9371 develops a voltage drop that causes the collector of transistor Q9301 to become low. As a result, the base voltage of Q9302 also becomes low causing its collector to go high. The output voltage is applied to IC9500 and IC9003 as DVR RST.

When the 5V SENSE circuit does not detect 5V from the C2 board, the DVR RST output becomes low. The unit goes into shutdown and the power LED blinks 12 times.

When troubleshooting 5 blinks SOS, isolating the C board and the panel may be necessary. To avoid having the power LED blink 12 times after disconnecting either D31/C11 or D32/C21, test point TP9010 should be shorted to ground.

Test Point TP9200 is the ideal location to check for DRV RST.



# Location of Q9302

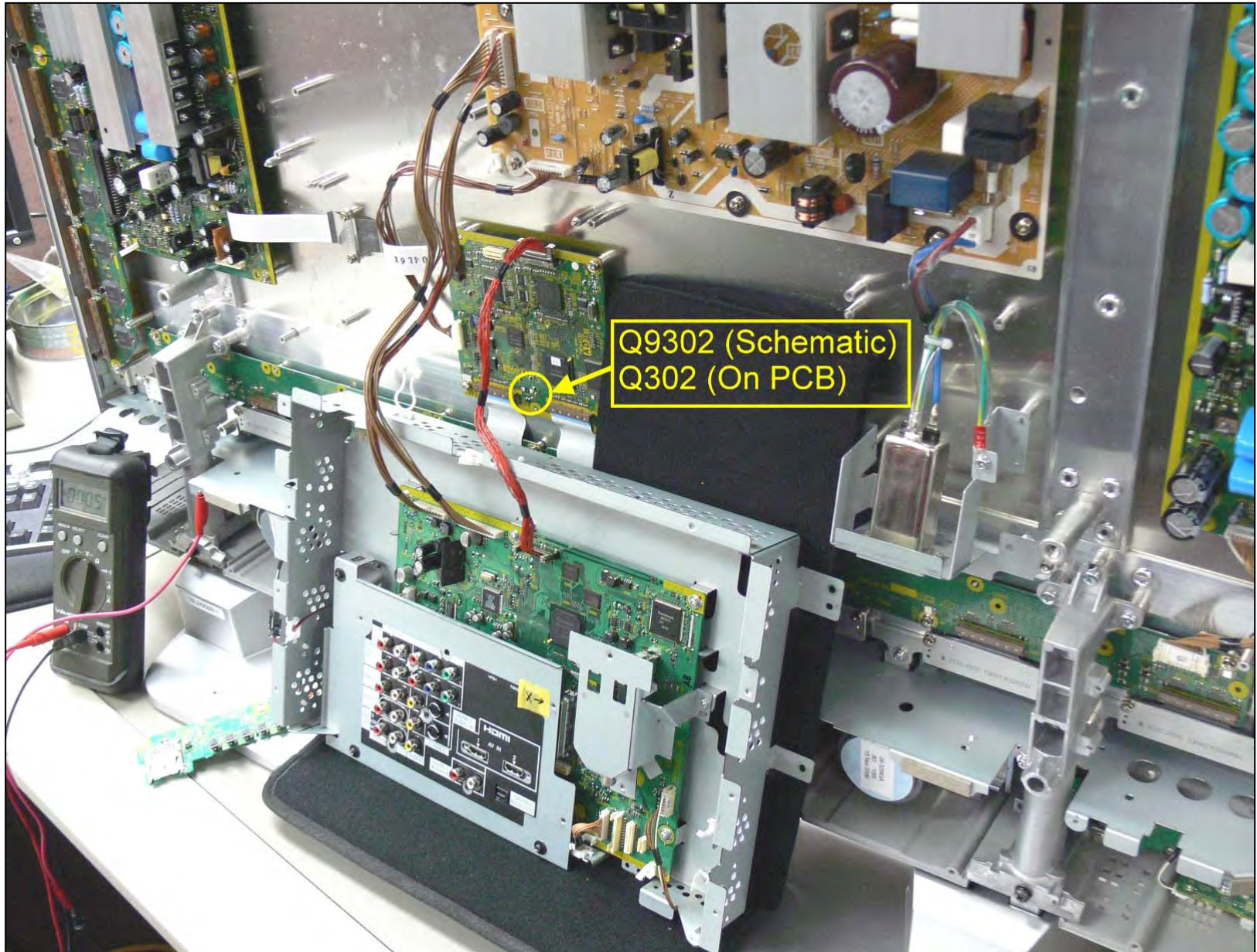



# Close-up View of Q9302

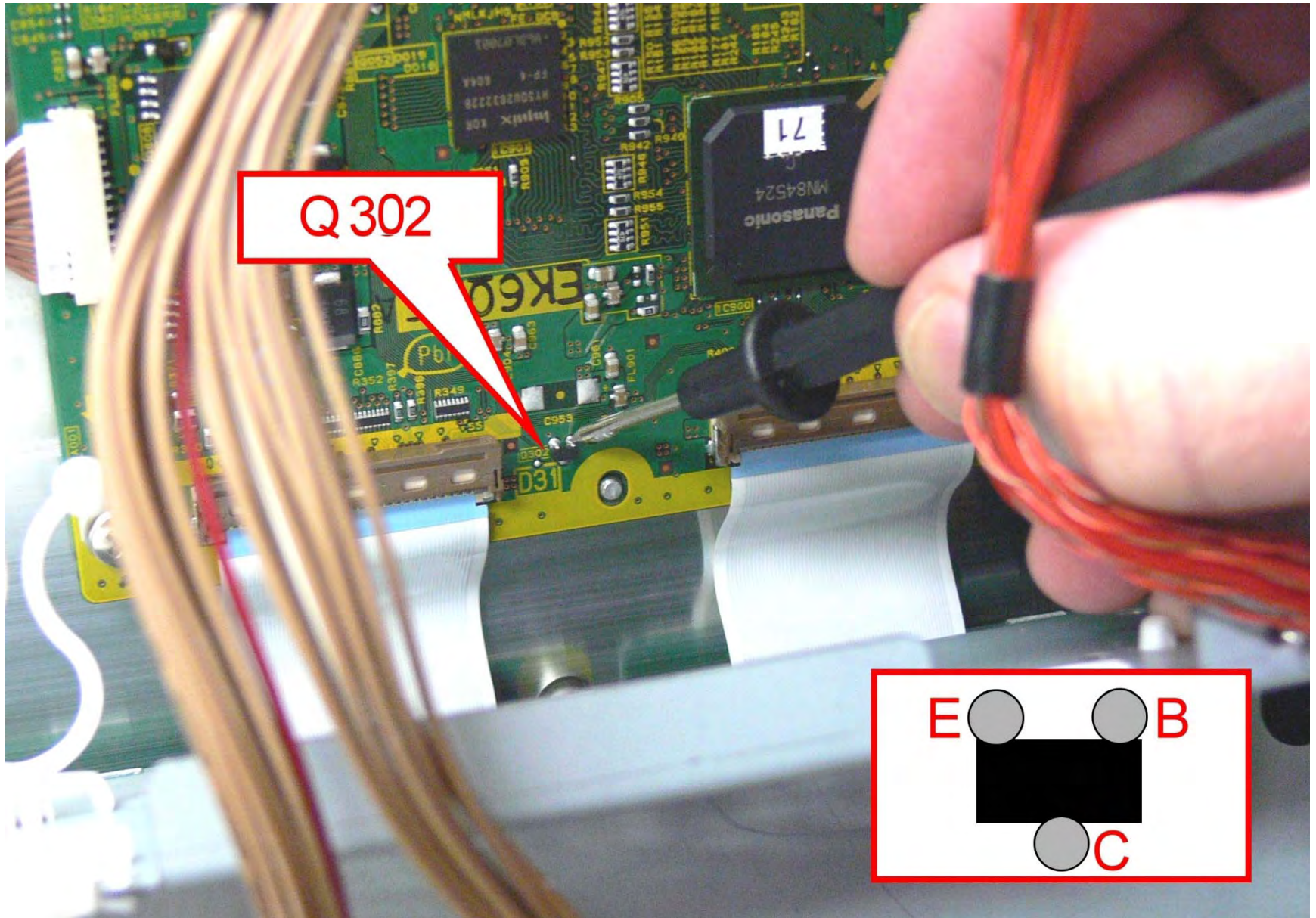

# 5 Blinks SOS (1)

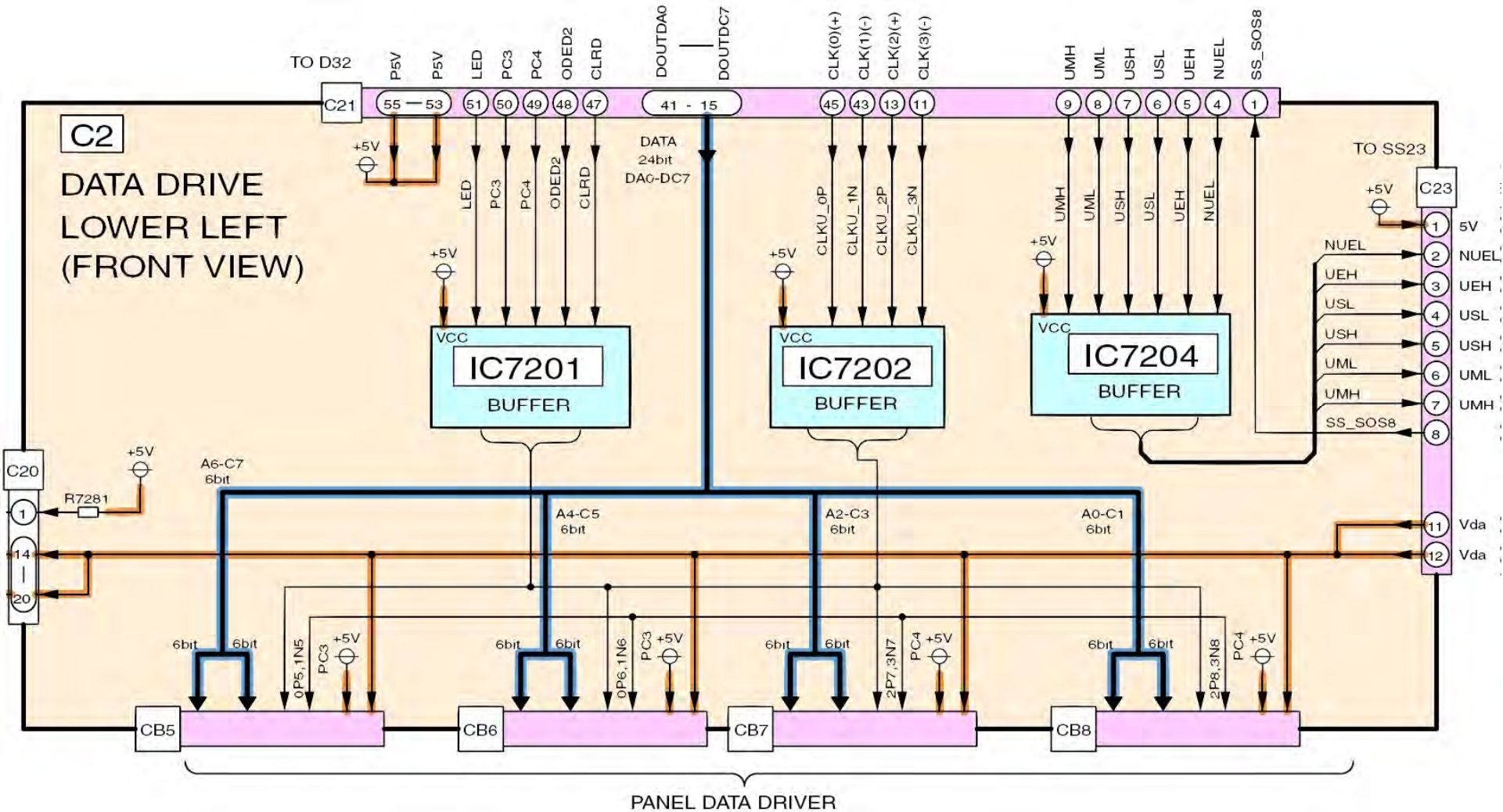



# 5 Blinks SOS (1)

The 5V SOS may be caused by a defective shift register located on a ribbon cable that connects the C boards to the panel. A shorted shift register typically shorts out both the Vda and 5V inputs. To determine whether a shift register is shorted or not, disconnect the connector SS23 and measure the resistance between pin 12 of the connector C23 and ground. The normal resistance is approximately 110000 ohms. If the panel is shorted, the resistance to ground is very low. If the panel is determined to be shorted, the left and right side of the panel can be isolated by disconnecting the connector C20/C10. Furthermore, the ribbon cables of the panel data electrodes can be disconnected one at a time until the short is no longer present.

# SOS (Drive-reset)

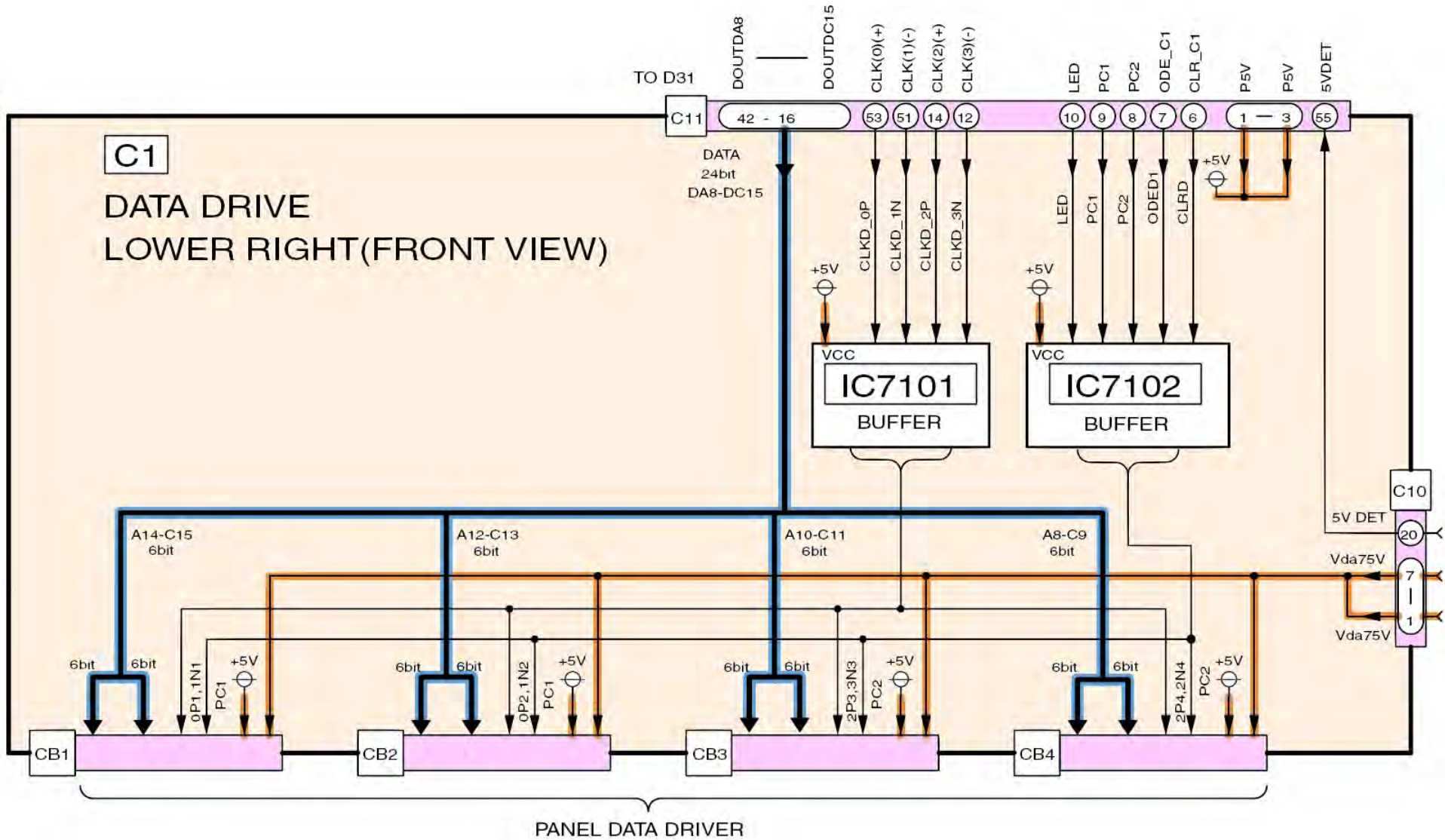

# D and C Boards Connection

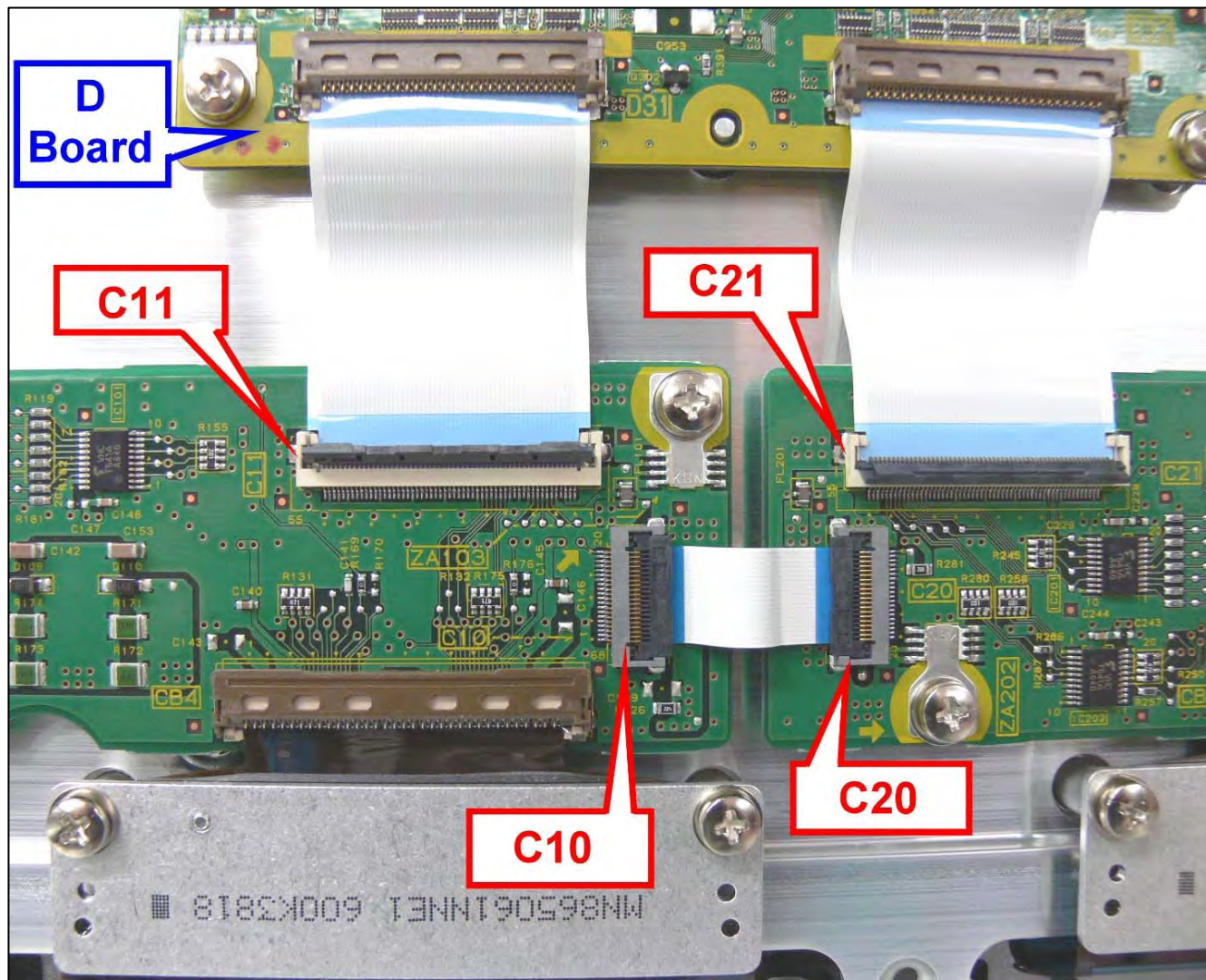

The improper connection of the connectors C11, C21, C10 and C20 causes a DVR\_RST SOS. The power LED blinks 6 times, leading one to believe that there is a problem in the audio output circuit.

## Caution:

1. The ribbon cable C10/C20 must be transferred during a panel exchange.
2. The improper installation of the connectors C11 and C21 may cause vertical lines to appear in the picture.



# 12 Blinks SOS

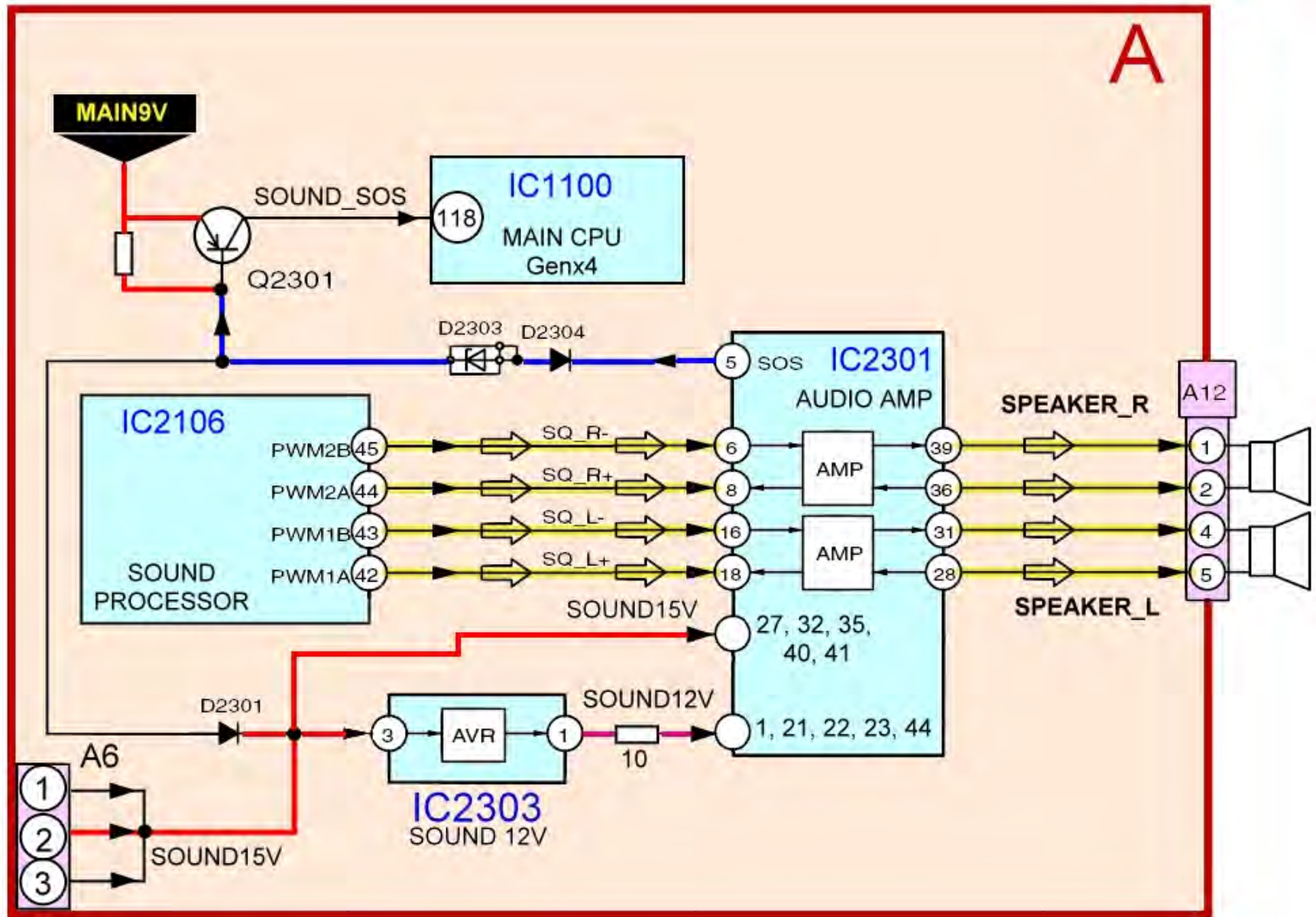

# 12 Blinks SOS

1. Sound processing and adjustments are performed by IC2106. The two channel PWM audio output of the IC is applied to the audio power amplifier IC2301. The PWM signals of the power amplifiers are output to the right and left channel speakers for sound reproduction.
2. IC2303 converts the 15V source to 12V for connection to the audio power amplifiers.
3. The diode D2303 and transistor Q2301 monitor pin 5 of the power amplifiers for excessive current drain. If a short circuit develops, transistor Q2301 goes into conduction and outputs a high to pin 118 of the MPU, IC1100, triggering an SOS condition.
4. A short circuit of the 15V line causes the diode D2301 to go into conduction. As a result, the base voltage of Q2301 becomes low and a high is output to the MPU to trigger an SOS condition.



## *Signal Processing*



# Signal Circuit Overview

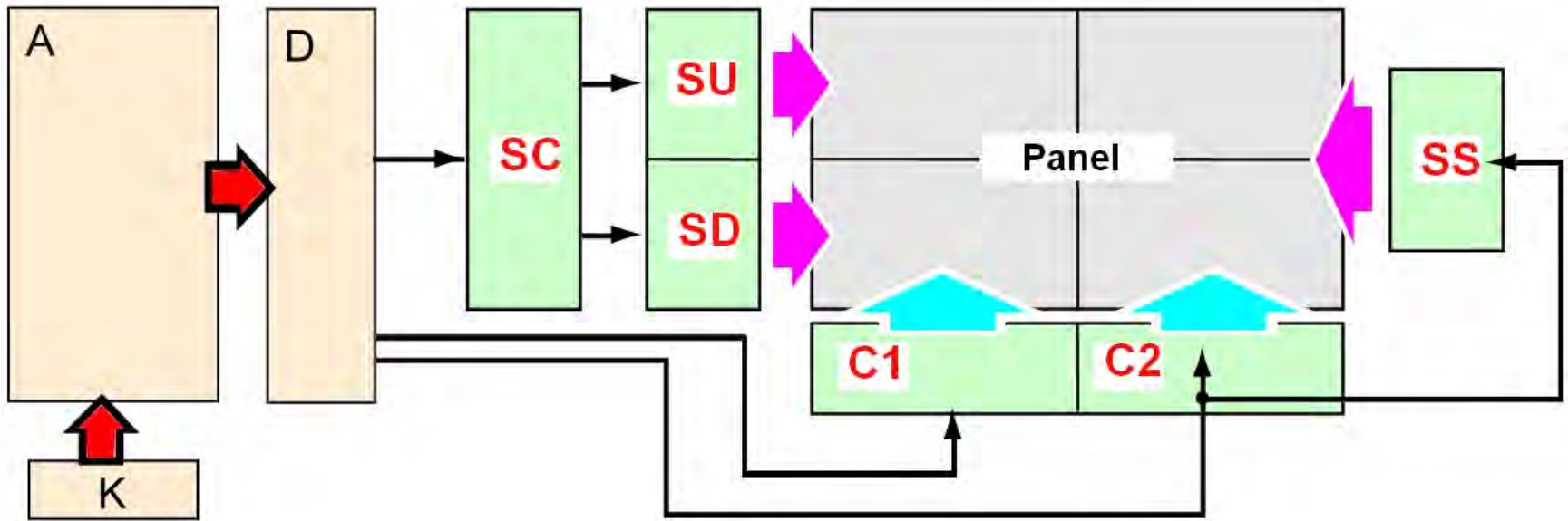

# Signal Circuit Overview

The K is the Remote Receiver and Power LED board. Commands that originate from the remote control or keypad of the GS board are received and processed by the system control circuit located on the A board.

The A board contains an Optical Audio Out jack for use with a Dolby Digital decoder and a multi-channel audio amplifier. When a digital channel is selected, the output from the Digital Audio Out jack is Dolby Digital. The same jack outputs PCM (Pulse Code Modulation) when any other signal source is selected.

NTSC, ATSC, and QAM television reception is performed by the A board. The unit also contains two video inputs, two HDMI inputs and two component inputs that are directly connected to the A board. The A board selects the video signal for display on the screen. It is responsible for converting all inputs into YUV data for video processing. The A board performs PIP (Picture in Picture) and picture control operations such as brightness, contrast, color, tint, etc. The PEAKS firmware of the unit also resides in this board. The RGB output of the A board passes through an LVDS (Low Voltage Differential Signaling) transmitter for conversion into serial data. The output signal is then applied to the D board.

The D board is responsible for displaying the picture. It provides the scan, sustain and data drive signals to address the panel. The scan pulses are output to the SC board. The sustain pulses are output to the SS board. The data drive signals are output to the C1, and C2 boards. The C1 board drives the right half of the panel; the C2 board drives the left half of the panel.

The SC board is responsible for the generation of the scan pulses. Scan pulses are used for initialization and selection of the pixels.

The SU and SD boards are de-multiplexer boards that are responsible for converting serial data output of the SC board into parallel data to drive the panel.

The SS board is responsible for the generation of the sustain pulses. Sustain pulses are used to initialize and control the brightness of the screen.

The SS2 and SS3 boards are extension (connector) boards used to connect the SS board to the panel.

# Video Process Block Diagram

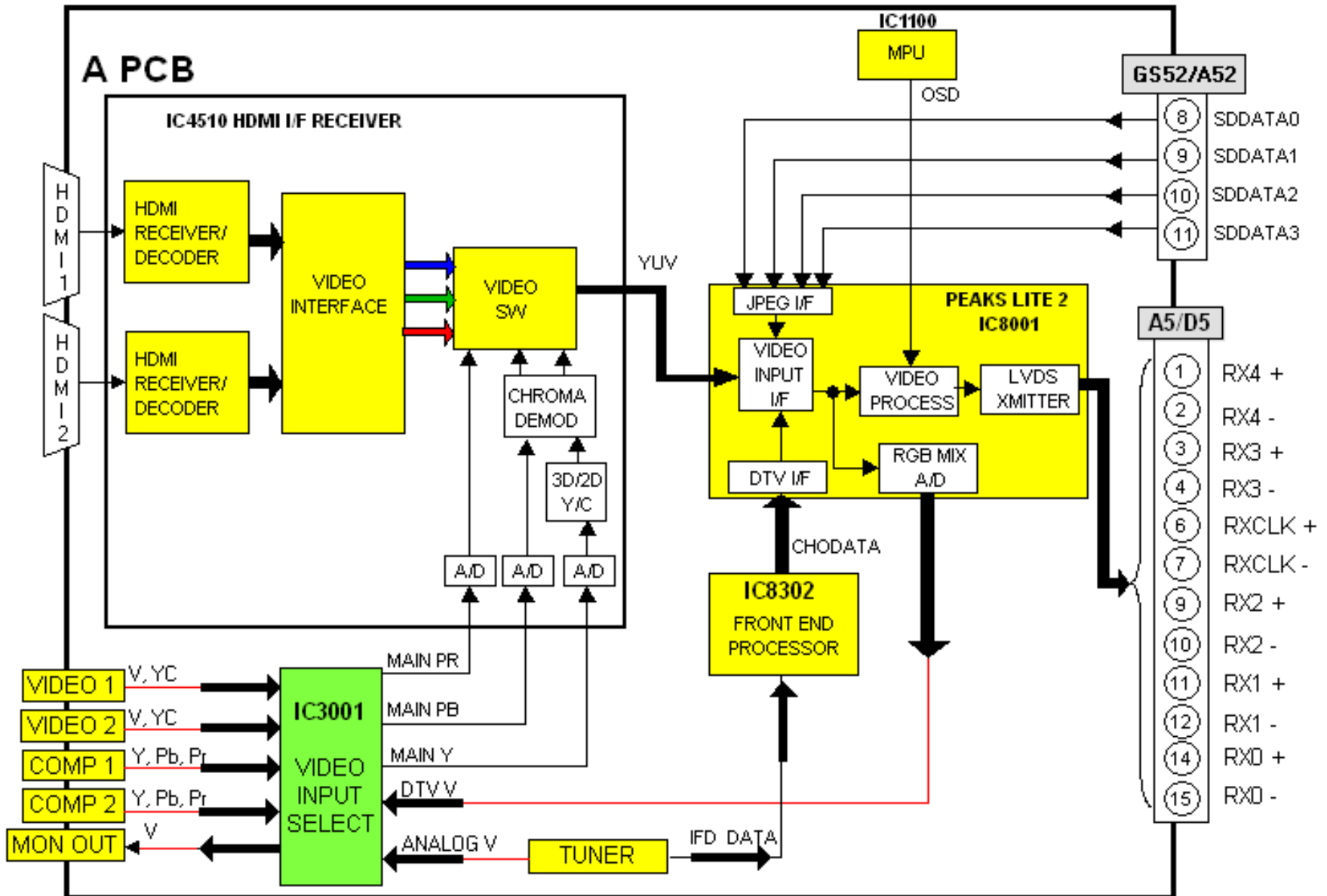



# Video Process Block Diagram

The main function of the A board is to select and process one of the incoming video signals. Video inputs 1 and 2, Component Video Inputs 1 and 2 and the composite video output of the tuner are all connected to IC3001 for selection. The video output signal of the switch can be in any of the three formats: Video, Y/C, or Y, Pb, Pr. The selected output enters IC4510, the HDMI IF Receiver/Decoder IC, for A/D conversion.

The comb filter inside IC4510 converts the composite video signal of the main picture to Y and C (luminance and chrominance) signals. S-Video, which is already Y/C separated, simply passes through the comb filter. The chrominance data is then applied to the Chroma Demodulator circuit to separate the color signal into Pb and Pr data. At the completion of this process, the format of the composite or S-Video signal is now the same as a digital 480i component signal. If the incoming video is in the 480p, 720P, or 1080i format, the Y, Pb, and Pr signals undergo A/D (analog to digital) conversion only. The 10 bit YUV data is provided to a video switch.

The HDMI receiver section of IC4510 converts the incoming HDMI signals to a YUV video signal. The Video interface circuit selects between the two HDMI sources and outputs the YUV signal to the switch. The output of the switch is provided to another switch located inside the PEAKS LITE IC, IC8001.

Digital television reception of the tuner is output in the form of an IF (Intermediate Frequency) signal. IC8302 contains a detector circuit that retrieves the Transport stream from the IF signal. The transport stream then enters the DTV I/F (Interface) section of IC8001 where the video signal is extracted and converted to YUV data. The output is provided to the Video Input I/F for selection. The JPEG data of the SD card enters the JPEG I/F section of IC8001 for conversion into YUV data and output to the Video Input I/F circuit. The video input interface outputs the selected picture data to the video process circuit.

This Video Process section of the IC performs all picture control operations such as brightness, contrast, color, tint, etc. On Screen Display data such as channel numbers, Digital TV closed caption, and picture adjustments are mixed with the video data. The output signal is then applied to the LVDS (Low Voltage Differential Signaling) transmitter for conversion into serial data. The LVDS transmitter transfers the video information from the A board to the D board. It distributes signals with low-jitter, while creating little noise. It reduces power consumption and the generated noise from data transmission. Another benefit of the LVDS standard is minimal concern for cable length.

The main MCU handles all video applications. It serves as the controller that monitors all operations of the TV section (not display) of the unit.

When watching digital television or viewing pictures from an SD card, the digital YUV output of the Video Input Interface is converted into analog composite video signal for output at the monitor out jack.

# D Board Block Diagram

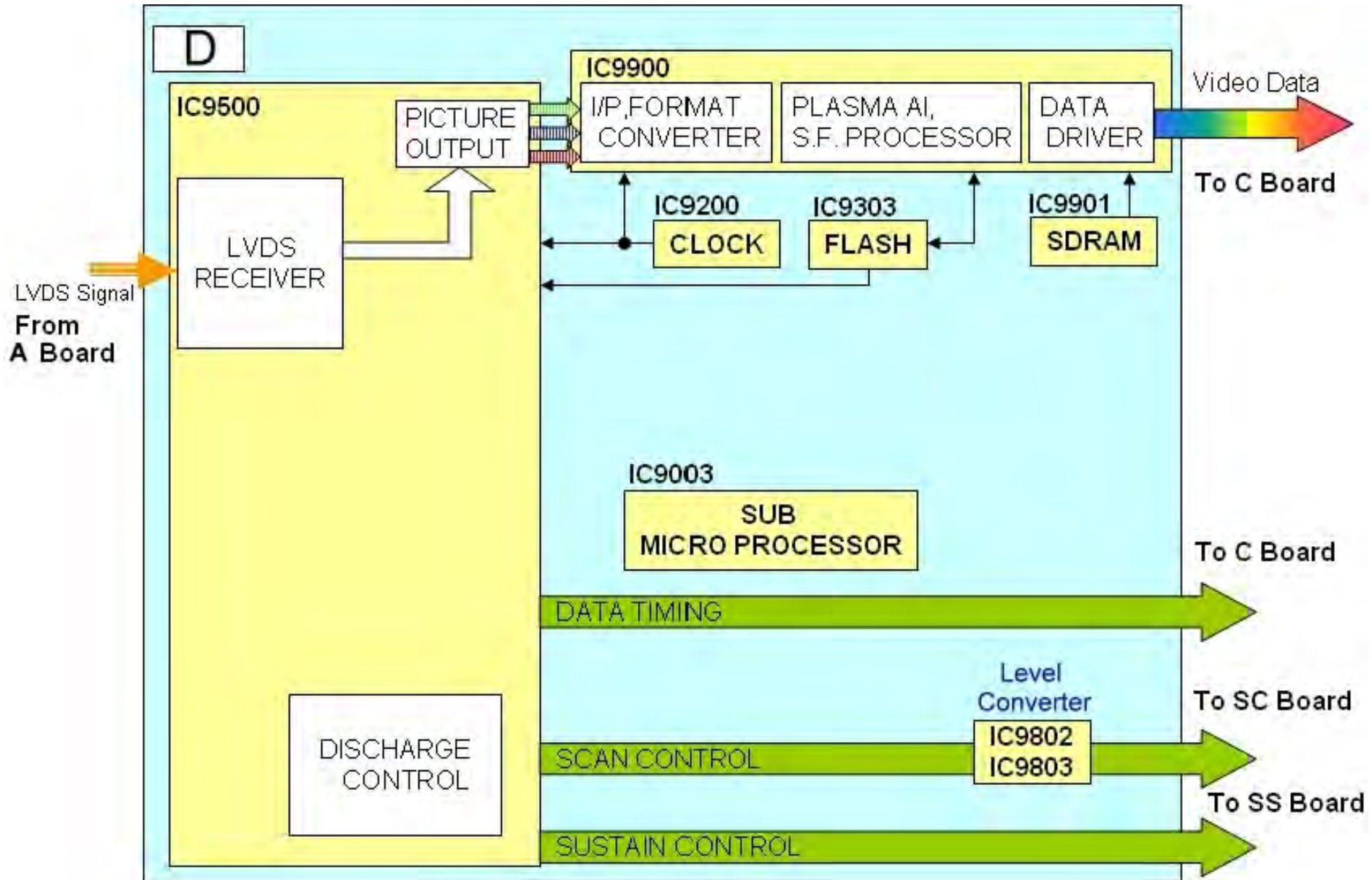

# D Board Block Diagram

Component	Function	Component	Function
IC9500	LVDS RECEIVER / DISCHARGE CONTROL	IC9802-3	LEVEL CONVERTER (3.3V => 5V)
IC9900	PLASMA AI / SUB-FIELD PROCESSOR	IC9303	FLASH MEMORY
IC9901	DDR SDRAM	IC9003	SUB MICRO PROCESSOR
IC9200	CLOCK GEN.		

## Discharge Control

IC9500 of the D board contains the Discharge Control circuit that analyzes the RGB and sync information of the video signal to create the Scan data to drive the Scan operation (SC) board and Sustain data to drive the Sustain operation (SS) board.

The SC board is responsible for the generation of the scan pulses. Scan pulses are used for initialization and selection of the pixels..

The SS board is responsible for the generation of the sustain pulses. Sustain pulses are used to initialize and control the brightness of the panel.

## Data Drive

The LVDS receiver inside IC9500 of the D board converts the video signal to 10 bit RGB data, the original format. The output is provided to IC9900.

IC9900 contains a format converter that changes the resolution of the signal to match the size of the panel. It also contains the Plasma AI (Adaptive brightness Intensifier) circuits that analyzes the APL\* for the distribution of dark and bright components. IC9900 subsequently converts the picture data into the 10, 11, or 12 subfields data to feed the two C boards.

The C boards are buffer boards that are used to distribute data to the shift registers of the panel.

The level converter ICs are level shifters that changes the voltage level of the data from 3.3V to 5V.

IC9200 is a clock generator.

IC9303 is a non-volatile memory chip that contains parameters for driving the panel.

IC9901 is a memory chip that is used for sub-field conversion.

# Panel Drive (TH-42PX75U)

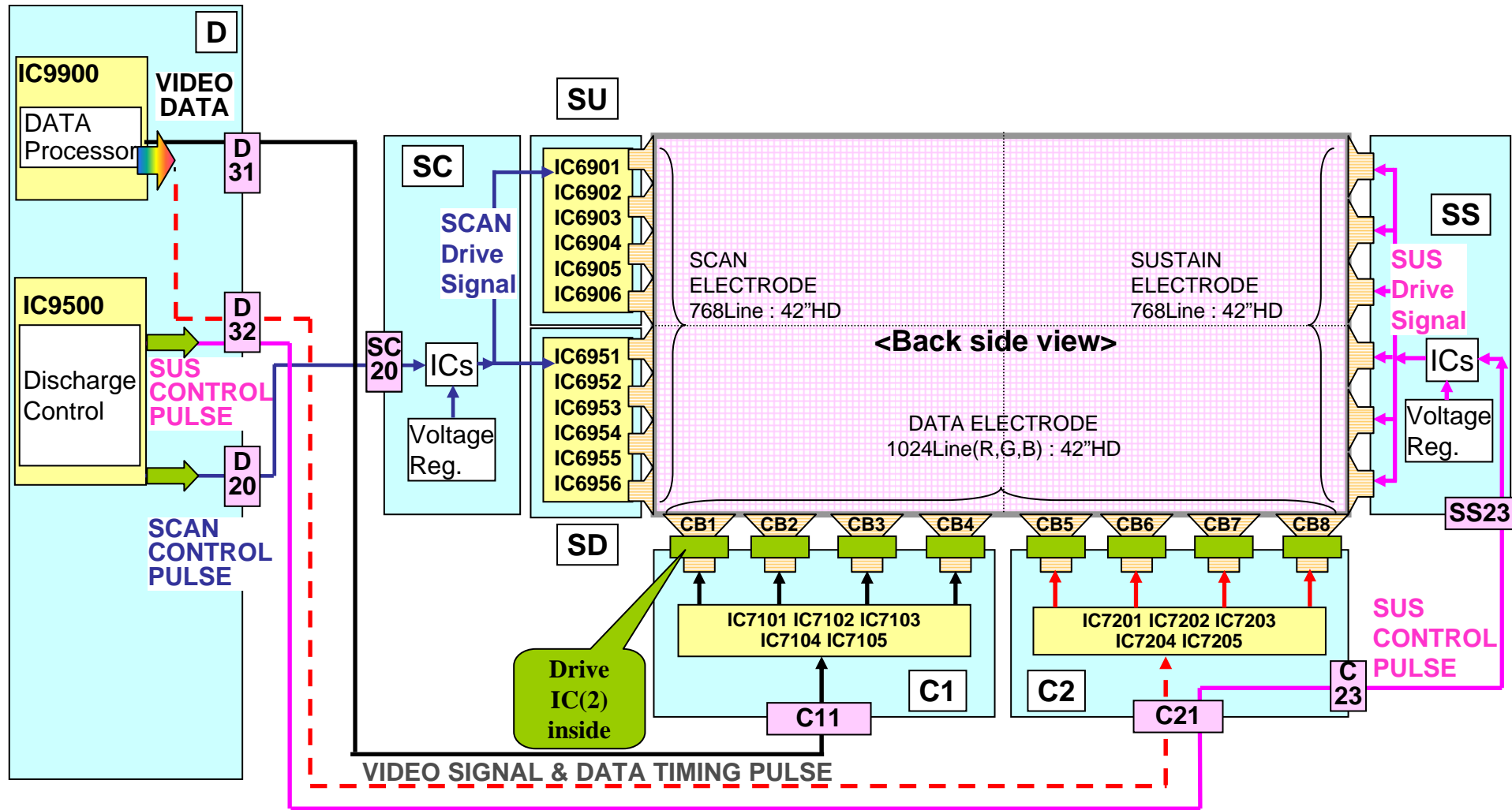

<SU Board>

IC6901-IC6906 : SHIFT REGISTER (UPPER)

<SD Board>

IC6951-IC6956 : SHIFT REGISTER (LOWER)

<C Board>

IC7XXXX : BUFFER

# Panel Drive (TH-42PX75U)

## Discharge Control

IC9500 of the D board contains the Discharge Control circuit that analyzes the RGB and sync information of the video signal to create the Scan data to drive the Scan operation (SC) board and Sustain data to drive the Sustain operation (SS) board.

The SC board is responsible for the generation of the scan pulses. Scan pulses are used for initialization and selection of the pixels. The SU and SD boards are de-multiplexer boards that are responsible for converting the serial data output of the SC board into parallel data to drive the panel. Each board drives one half of the panel horizontally.

The SS board is responsible for the generation of the sustain pulses. Sustain pulses are used to initialize and control the brightness of the panel.

## Data Drive

IC9900 memorizes the 10 bit data into two field data to drive the left and right side of the panel. IC9900 subsequently converts the picture data into the 10, 11, or 12 subfields data to feed the data electrodes of the panel.

The data drive signal of IC9900 is output to the C boards. The C boards are buffer boards that are used to distribute data to the shift registers of the panel.



# Audio Process Block Diagram

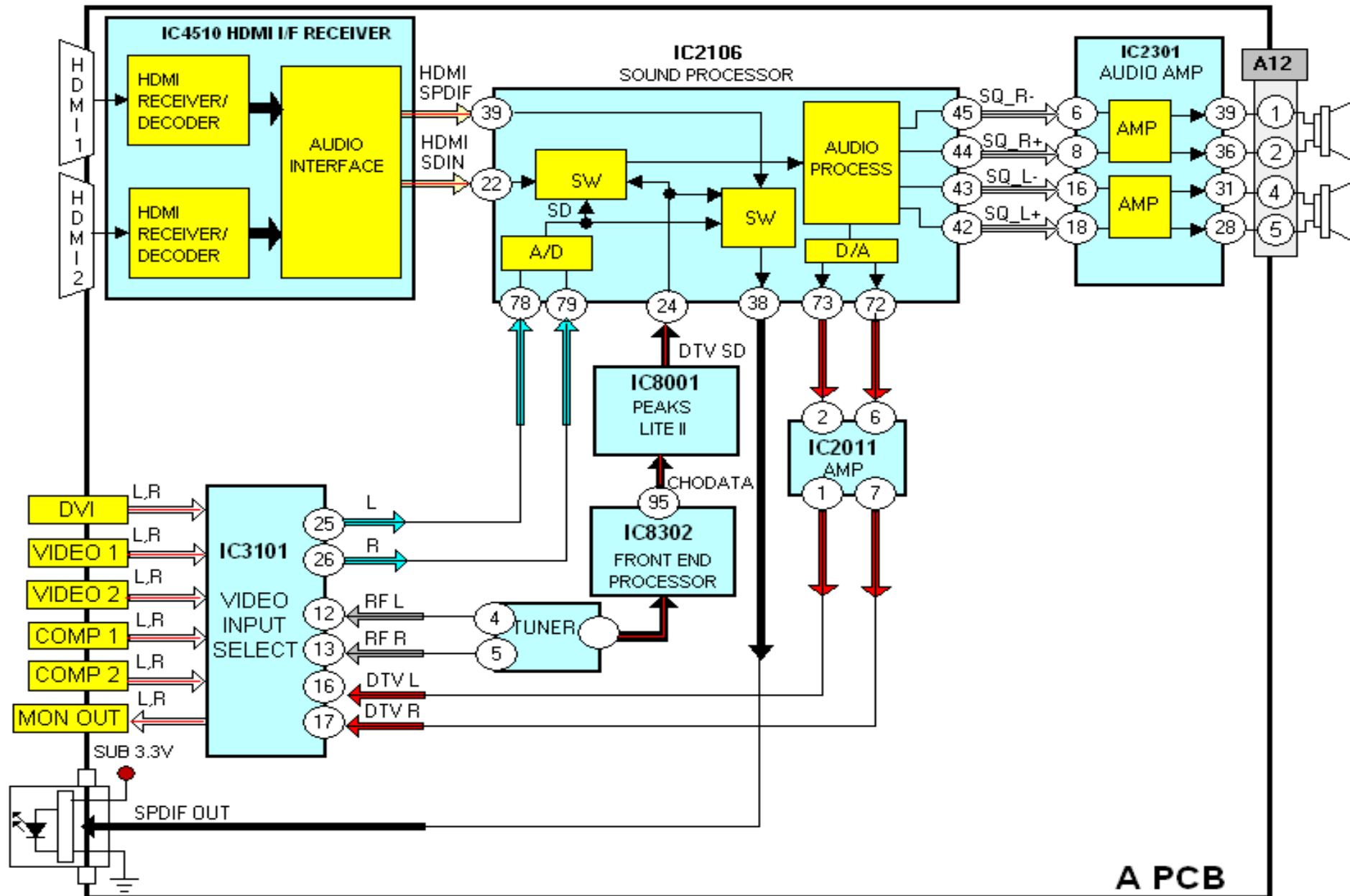

A PCB

# Audio Process Block Diagram

IC3101 of the A board handles the audio selection of most inputs. Analog Audio signals from composite, component, and DVI inputs are connected to IC3101 for selection. The analog audio of the tuner is also provided to IC3101 for selection. The output of IC3101 enters IC2106 and undergoes analog to digital conversion. The serial data output is provided to the switch. The HDMI receiver section of IC4510 converts the incoming HDMI audio into serial data. The Audio interface circuit selects between the two HDMI audio and outputs the SD (serial Data) to the switch located inside IC2106.

Digital television reception of the tuner is output in the form of an IF (Intermediate Frequency) signal. IC8302 contains a detector circuit that retrieves the transport stream from the IF signal. The transport stream then enters The DTV I/F (Interface) section of IC8001 where the audio signal is extracted and converted to serial data. The output is provided to the switch located inside IC2106. The output of the switch enters the Audio Process section of the IC. Volume, bass, treble, and balance adjustments of the audio signal are performed by this circuit. The output is two channel PWM data that are applied to IC2301 for amplification. The PWM output signals of the power amplifier are output to the right and left channel speakers for sound reproduction.

The Monitor output connection of IC3101 provides left and right channel audio output for connection to an external audio amplifier. HDMI PCM (Pulse Code Modulation) Audio and DTV AC3 audio are connected to the optical audio output jack via a switch located inside IC2106.



## *Adjustments*





# Self-Check Function

1. Checks the communication IIC bus lines
2. Provides a SOS History

To Access the Self-Check Mode, turn the TV on and while pressing “VOLUME ( - )” button on the main unit, press the “OK” button on the remote control for more than 3 seconds.

**TV volume down & OK on remote only does a basic IC self check. It does NOT restore the unit to factory shipping settings.**

It does not clear channel programmed settings, picture settings, channel labels, LOCK mode settings, or password.

Using this method, it shows the unit’s firmware version (Peaks 1.050 and GenX 1.00) and it checks IIC communications ONLY.

This is more useful to identify the firmware version without having to decode the info in the setup menu “About/Version” screen.

To Exit the Self-Check Mode, Press and hold the Power button on the TV for 5 seconds or disconnect the AC cord from the wall outlet.

# How to Reset the Unit

**Note: All customer programmed parameters will be erased.**

To Reset the Unit, turn the TV on and while pressing the “VOLUME ( - )” button on the main unit, press the “Menu” button on the remote control for more than 3 seconds. The Self-Check menu appears on screen. Then, disconnect the AC cord from the wall outlet.

# Self-Check Menu

**SELF CHECK**

0.470 - 00.16

DT	<b>08</b>
GC3FS	OK
ADV	OK
VSW	OK
ADAV	OK
ASW	OK
TUN1	OK
TUN2	OK
FE	OK
GenX4	OK

MEM1	OK
MEM2	OK
PANEL	OK
TEMP	OK

ROMCORR.CHECKSUM:00

**SOS : 01**

Copyright 2007 Matsushita Electric Industrial Co.,Ltd.

# Check point

DISPLAY	Ref. No.	Description	P.C.B.
DT	IC8001	Peaks Lite2	A-Board
ADV	IC4510	A/D CONV. , HDMI RX	A-Board
VSW	IC3001	VIDEO SW	A-Board
ADAV	IC2106	SOUND PROCESSOR	A-Board
ASW	IC3101	AUDIO SW	A-Board
TUN1	TU8300	TUNER (PLL block)	A-Board
TUN2	TU8300	TUNER (MTS block)	A-Board
FE	IC8302	Digital demodulator	A-Board
GenX4	IC1100	GenX4 (STB MCU)	A-Board
MEM1	IC1101	EEPROM (GenX4)	A-Board
MEM2	IC8503	EEPROM (Peaks)	A-Board
PANEL	IC9003	MICON	D-Board
TEMP	IC9002	TEMP SENSOR	D-Board

# Serviceman Mode

**To enter the Serviceman Mode**, turn the TV on and while pressing the “VOLUME ( - )” button on the main unit, press the “RECALL” button of the remote control three times within 3 seconds.

**To exit the Serviceman Mode**, Press the Power button on the TV or the Remote Control.



# Serviceman Mode Menu and Navigation

SERVICE	Peaks SOFT	0.470
ADJUST	Peaks EEp	0.16
WB-ADJ	LSI DATA	0.00.31
OPTION	GenX SOFT	0.22.00
AGING	GenX ROMCOR	f.ff.ff
RM-SET	FPGA	-,--
SRV-TOOL	PDP SOFT	01.00
	PDP EEP	40.12
	PDP FPGA	40.15
	PDP PDROM	40.53
	SDMODULE	-,----

NOTE: This is not part of the Menu

## Key command

“1” button...Main items Selection in forward direction

“2” button...Main items Selection in reverse direction

“3” button...Sub items Selection in forward direction

“4” button...Sub items Selection in reverse direction

“VOL” button...Value of sub items change in forward direction ( + ), in reverse direction ( - )

# Adjustment Sub Menu

ADJUST  
CONTRAST  
YMAX

VIVID  
000

1, 2: MAIN SELECT  
3, 4: SUB SELECT  
9 : PICTURE MENU SELECT  
OK 3sec: AUTO ADJUST  
VOL: ADJUST

# Internal Test Patterns

To access the internal patterns, select [**AGING**] from the main adjustment menu and press the [**3**] or [**4**] button of the remote control to select the desired pattern.

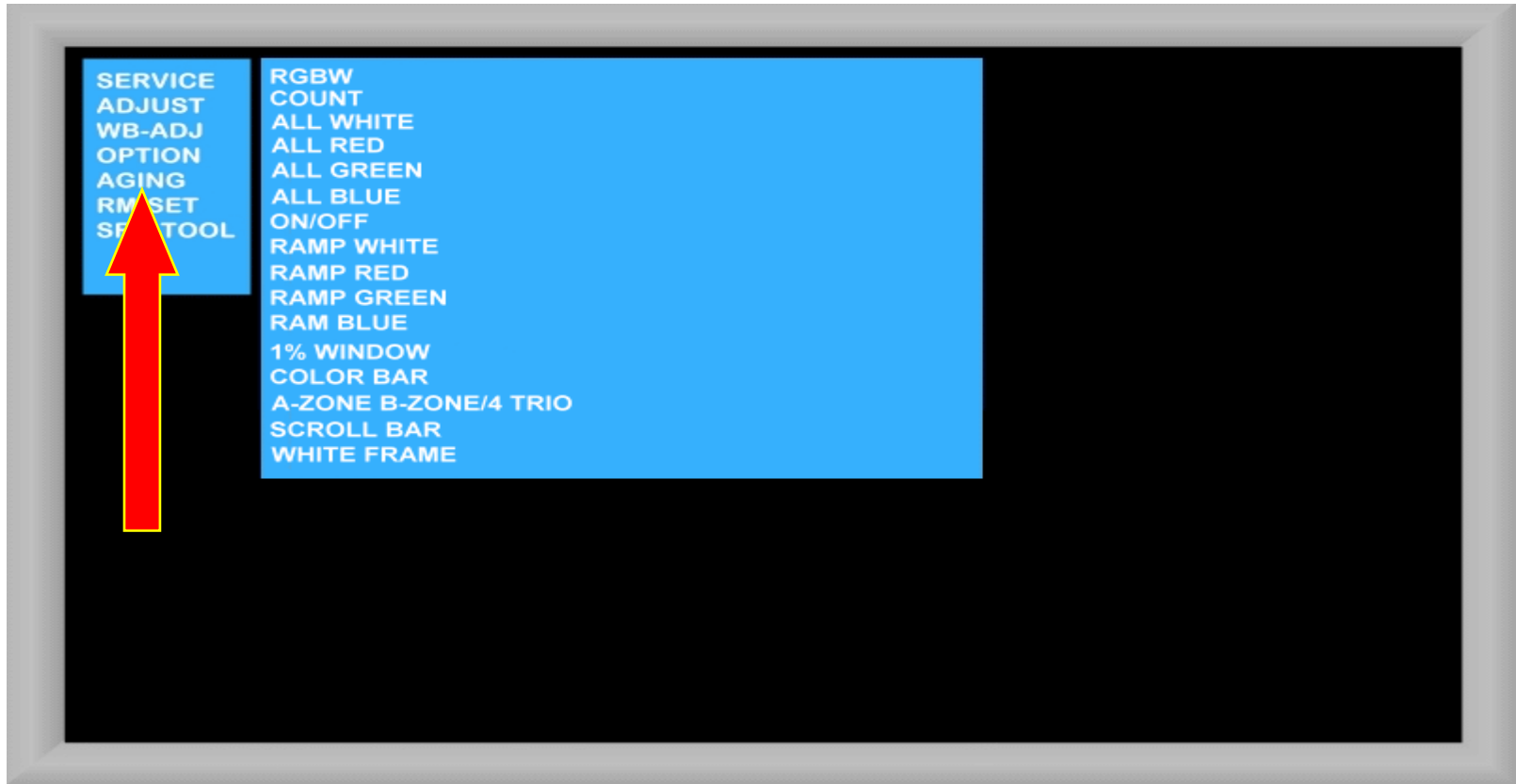

**To exit the Serviceman Mode**, Press the Power button on the TV or the Remote Control.

# Driver Setup Adjustment

## Driver Set-up

### Item / Preparation

1. Input a white signal to one of the unit's video input.
2. Set the picture controls as follows:  
Picture menu: Vivid  
Normal: Set  
Aspect: Full

### Caution

1. Perform the Vsus adjustment.
2. Confirm the voltage level of VSCN.  
This should be done after the adjustment of Vad which should be -105V

When Vad = -105V, Vscn voltage is 35V ±4V.

**Note:** See the panel label for voltages that are not listed in the service manual.

Name	Test Point	Voltage	Volume	Remarks
Vsus	TPVSUS (SS)	Vsus ± 2V	R628 (P)	*
Ve	TPVE (SS)	Ve ± 1V	VR6000 (SS)	*
Vset	TPVSET (SC)	330V ± 7V	Fixed	
Vad	TPVAD (SC)	-105V ± 1V	VR6600 (SC)	
Vscn	TPVSCN (SC)	Vad+145V ± 4V	Fixed	
Vda	TPVDA (SS)	75V ± 1V, -2V	Fixed	
PFC	C446(+)(-)	396.0V±0.5V	R443 (P)	

### Panel Label information

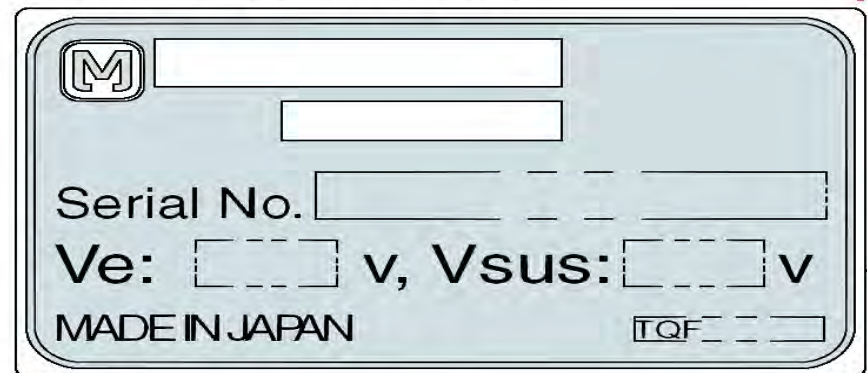

# Initialization Pulse Adjustment

1. Input a 100% White signal to the unit.
2. Set the picture controls as follows:  
Picture menu : Vivid  
Normal : Set  
Aspect : Full
3. Connect an Oscilloscope to test point TPSC1. Using VR6602, adjust (T2) for  $195 \pm 10 \mu\text{Sec}$ .

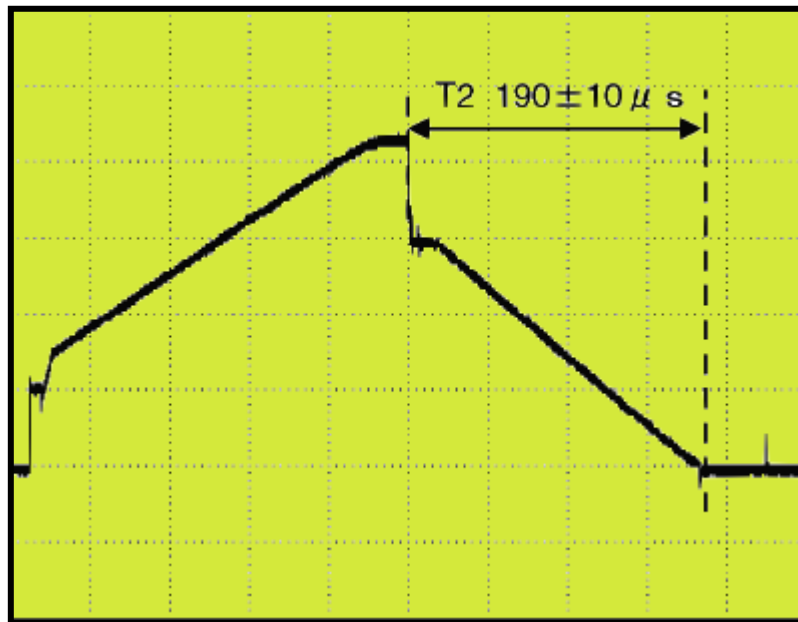



# Quick adjustment after P.C.B. exchange

## 1. Caution

Wait 1 minute for the electrolytic capacitors to discharge before removing any PCB from the unit.

## 2. Quick adjustment after P.C.B. or Panel exchange

P.C.B.	Name	Test Point	Voltage	Volume	Remarks
P Board	Vsus	TPVSUS (SS)	$V_{sus} \pm 2V$	R628 (P)	*
	PFC	C446 (+) (-)	$396.0V \pm 0.5V$	R443 (P)	
SC Board	Vad	TPVAD (SC)	$-105V \pm 1V$	VR6600 (SC)	
SS Board	Ve	TPVE (SS)	$V_e \pm 1V$	VR6000 (SS)	*
D, DG Board	White balance and Sub brightness for NTSC, PAL, HD, PC and 625i signals				